



# LX10.2

*Voltage regulator for generators*

**Instruction Manual V2.0**

Product version V2.0.0.0



**EMRI ELECTRONICS**  
**POWER IN CONTROL**



# WARNINGS AND COMMISSIONING INFORMATION



## HAZARDOUS VOLTAGES.



### DO NOT OPERATE WHEN NOT FAMILIAR WITH GENERATORS.

- **Check the isolation of the generator windings before installation.**  
**Poor isolation will cause damage to the AVR and dangerous situations for persons.**
- The system should not be installed, operated, serviced or modified except by qualified personnel who understand the danger of electric shock hazards and have read and understood the user instructions.
- Never work on a LIVE generator. Unless there is another person present who can switch off the power supply or stop the engine.
- Dangerous voltages are present at the voltage regulator board. Accidental contact with live conductors could result in serious electrical shock or electrocution.
- Disconnect the power source before making repairs, connecting test instruments, or removing or making connections to the voltage regulator or generator.
- Defects in the generator or AVR may cause consequential loss. Precautions must be taken to prevent this from occurring.
- The unit should be installed with respect to the environmental specifications as well as the rules mentioned in the General installation information.
- For safety reasons the voltage level potentiometers are best turned completely counter clockwise in order to start at the lowest possible voltage.
- Never change the rotary switch or dipswitch settings during operation.
- Never apply supply voltage when generator is not running, unless exciter field is disconnected.

## REVISION HISTORY

Product	Version			Change
	Hardware	Manual	Date	
<b>V1.0.0.0</b>	1.0	1.1	Jun-2015	<i>Added option for AFD (DUAL CHANNEL AVR). Changed droop input, added CT selection.</i>
<b>V1.1.0.0</b>	1.0	1.2	Mar-2017	<i>New manual layout.</i>
<b>V2.0.0.0</b>	2.0	2.0	Aug-2021	<i>Maximum rating: Increased excitation current and temperature range</i>

The table provides a historical summary of the changes made to the AVR.  
Revisions are listed in chronological order.

The manual does not cover all technical details of the product. Specifications may be modified by the manufacturer without notice. For further information, the manufacturer should be contacted.

# TABLE OF CONTENTS

General description .....	3
Absolute maximum ratings .....	4
Protections .....	5
Modes of control .....	6
Commissioning set up .....	9
Quick reference .....	10
Wiring diagrams .....	12
Tips and Suggestions .....	16
General installation information .....	19
Contact .....	20

## GENERAL DESCRIPTION

The LX10.2 is designed for use in brushless generators and can be used as a cost effective universal replacement for a great variety original manufacturers AVR's.

The LX10.2 can be used for parallel operation with other generators that also control voltage droop by means of Quadrature Droop Compensation (QDC).

Parallel operation is possible with an additional droop CT, which can be 0.5 or 1A secondary.

Installation, maintenance and adjustment don't require special application software.

The AVR is protected from the environment by a PUR coating.

<b>Mode of control</b>
Constant voltage control
Quadrature voltage droop for parallel operation
<b>Protection</b>
Generator phase loss
Excitator output limiting
User adjustable underspeed knee
<b>Communication</b>
Underspeed LED

# ABSOLUTE MAXIMUM RATING

Symbol	Parameter	Condition	Min.	Max.	Unit
U, V, W	Voltage sensing input <b>230Volt</b>	50-60Hz, continuous.	-	290	V <sub>AC</sub>
	Voltage sensing input <b>400Volt</b>	50Hz, continuous.	-	450	V <sub>AC</sub>
		50Hz, Intermitted < 10s.	-	480	V <sub>AC</sub>
		60Hz, continuous.	-	500	V <sub>AC</sub>
+, -	AVR field current	Continuous, Tamb 70°C. <sup>(1) (3) (4)</sup>	-	10	A <sub>DC</sub>
		Continuous, Tamb 55°C. <sup>(1) (3) (4)</sup>	-	15	A <sub>DC</sub>
		Intermitted < 10s. <sup>(1) (3)</sup>	-	17	A <sub>DC</sub>
	Field resistance	@ 70V <sub>AC</sub> supply <sup>(2) (3)</sup> @ 170V <sub>AC</sub> supply	5 12	- -	Ω Ω
LH1, LH3 LH2, LH4	Supply input	Isolated, DC or 25 - 400Hz.	20	300	V <sub>AC</sub>
		NO DC at terminal LH1	23	135	V <sub>DC</sub>
LH1, LH3	Supply input for self excitation	Minimum supply for self excitation EX-EX linked for self excite.	5	-	V <sub>AC</sub>
X1, X2	Droop CT 0.5A	Isolated CT < 30s. (J1-J2: open)	-	1	A <sub>AC</sub>
	Droop CT 1A	Isolated CT < 30s. (J1-J2: link)	-	2	A <sub>AC</sub>
T <sub>AMB</sub>	Operating temperature	95% RHD non condensing <sup>(1) (4)</sup>	-40	+70	°C
T <sub>STG</sub>	Storage temperature	95% RHD non condensing	-40	+70	°C
	Static control accuracy			1	%

<sup>(1)</sup> Always mount with heatsink fins aligned vertically and allow for sufficient airflow.

<sup>(2)</sup> See formula for calculating minimum field resistance

<sup>(3)</sup> See table below for safe operation area of the AVR.

<sup>(4)</sup> See table below for operation temperature of the AVR.



$$\text{Field resistance } (\Omega) \geq \frac{\text{Supply input} \times \sqrt{2} \text{ (V}_{DC}\text{)}}{20}$$



Stresses above “Absolute Maximum Ratings” may cause permanent damage to the device. This is a stress rating only, the functional operation of the device or any other conditions indicated in the “operation area” of this specification is not implied. Exposure to maximum rating conditions for extended periods may affect device reliability and lifetime.

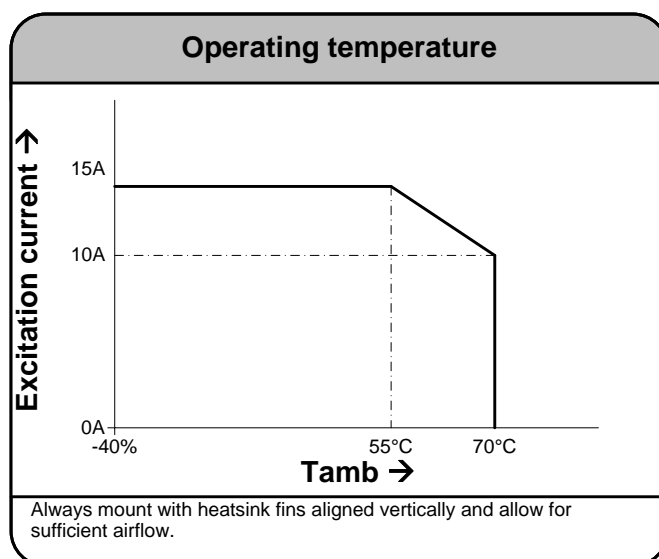
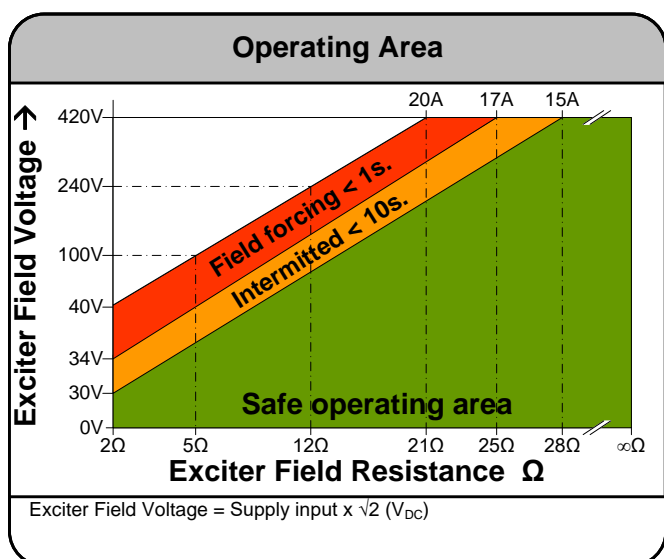

# PROTECTIONS

## Phase loss protection

Dip 2

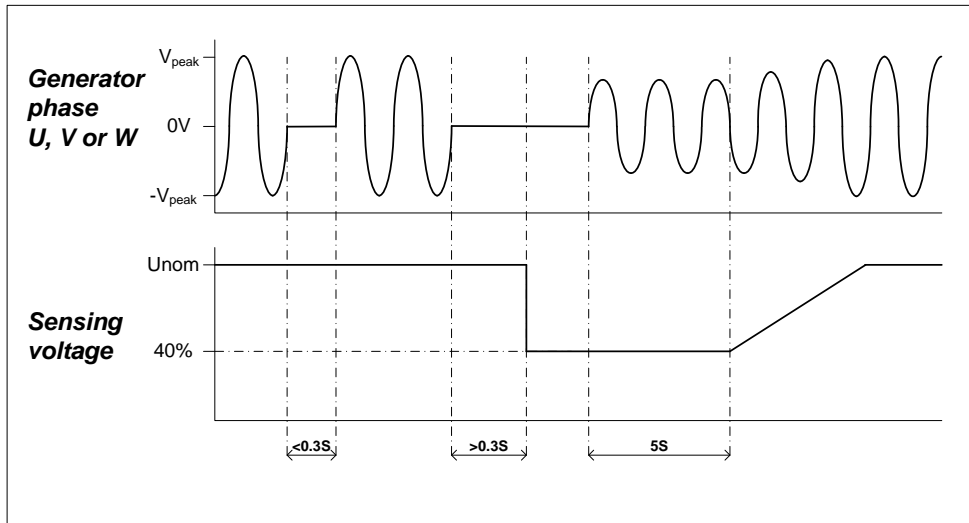

The phaseloss protection validates the presence of all three generator phases on the sensing terminals U, V and W . When one of the three phases is not sensed anymore for more than 300ms the AVR decreases the generator voltage setpoint to  $\pm 40\%$  of  $U_{nom}$ . If the error condition is relieved for 5s, the generator voltage is ramped up again to nominal voltage.

Default the phase loss protection is disabled.

## Fuse protection

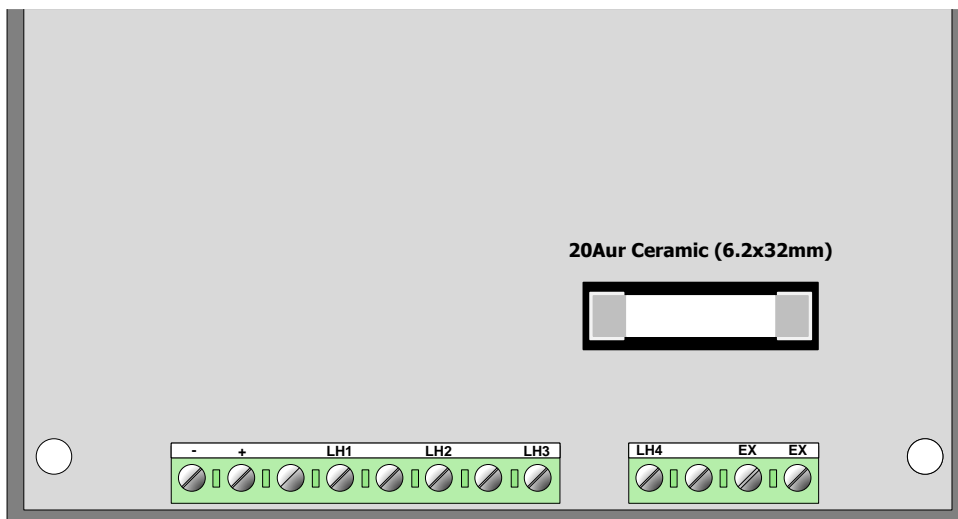

To prevent consequential damage in case of an AVR or generator failure, the AVR supply is fused by a 20A ultra rapid fuse.

Blowing the fuse will interrupt the field excitation output and causes the generator to de-excite.

When replacing the fuse, a 20A ultra rapid type fuse with dimensions 6.2 x 32mm must be used.

# MODES OF CONTROL I

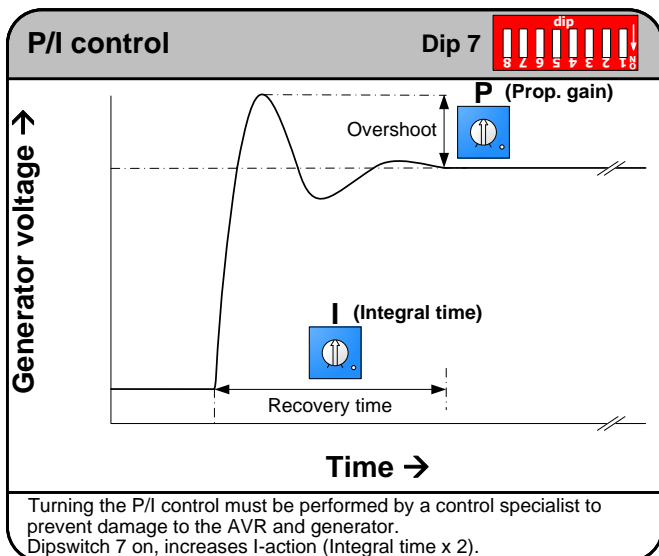
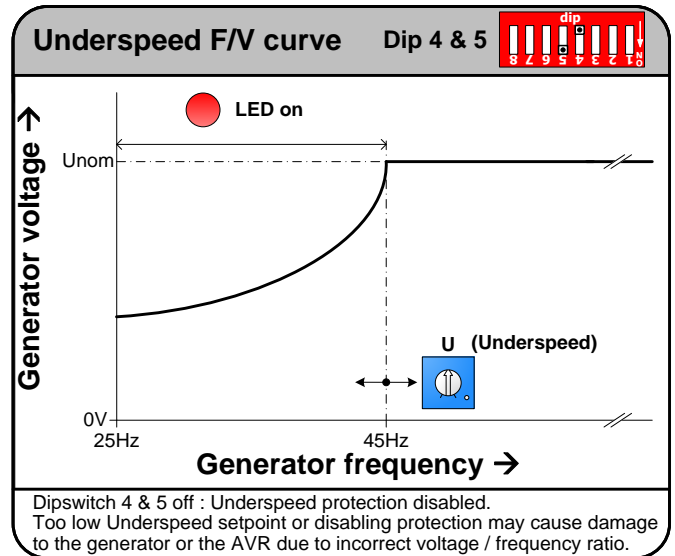
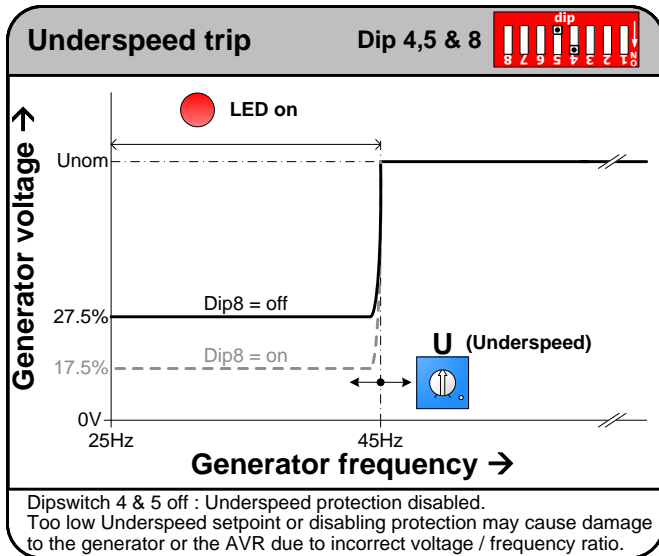
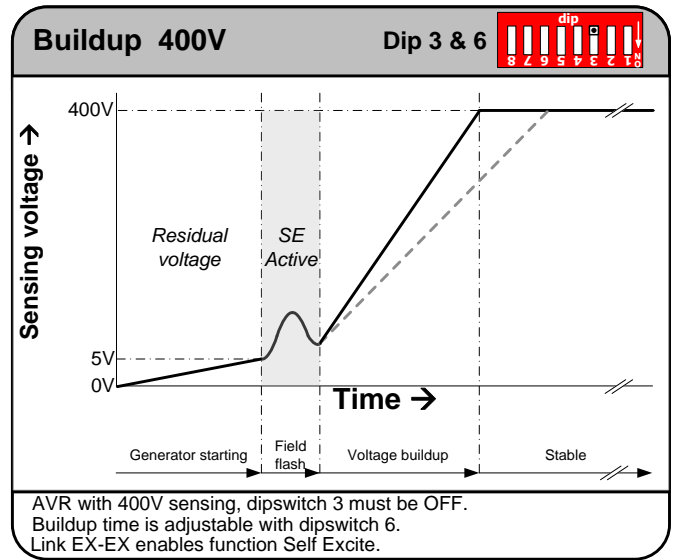
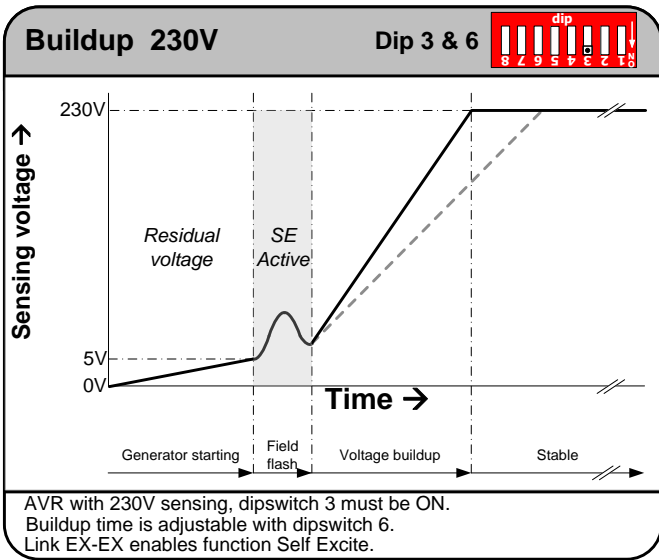

# MODES OF CONTROL II

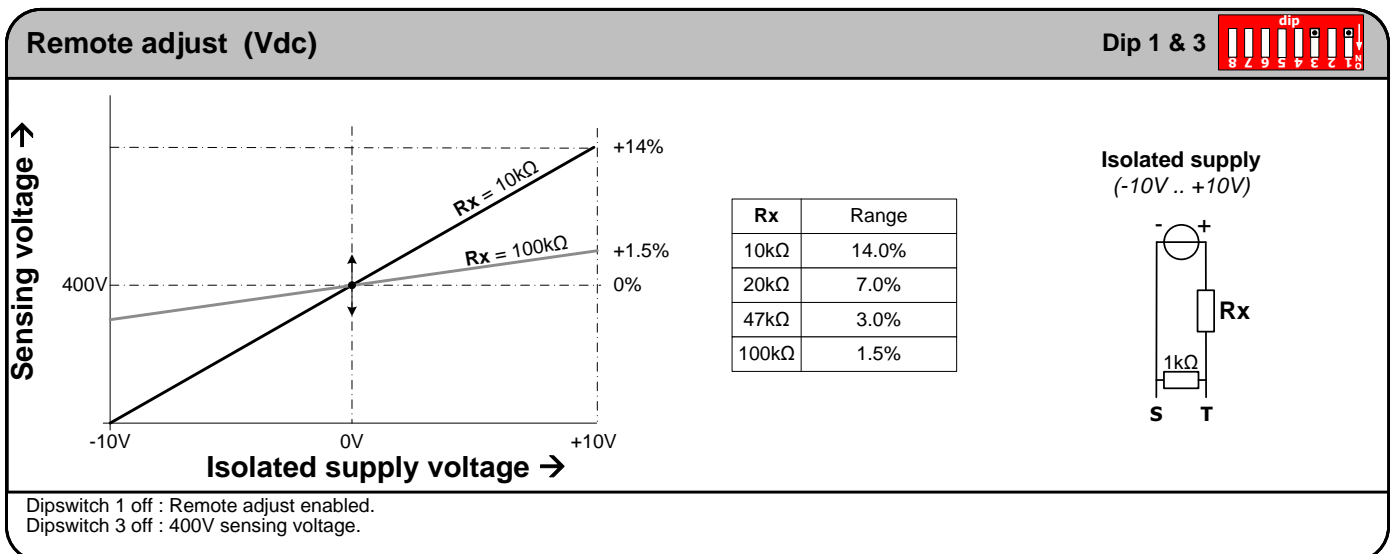
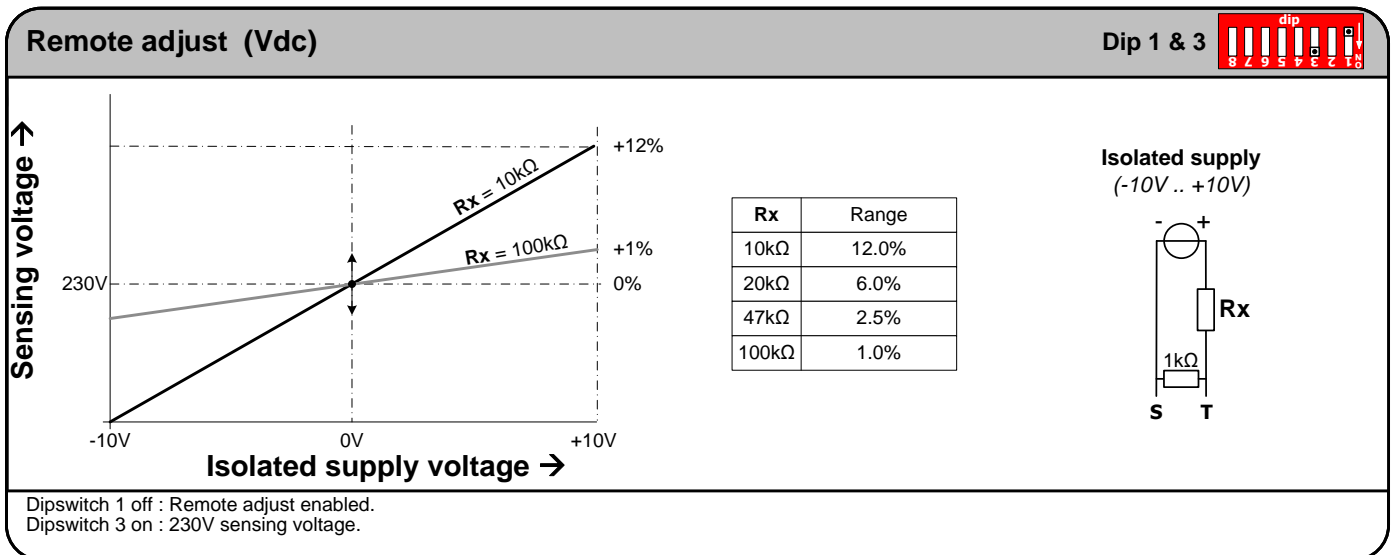
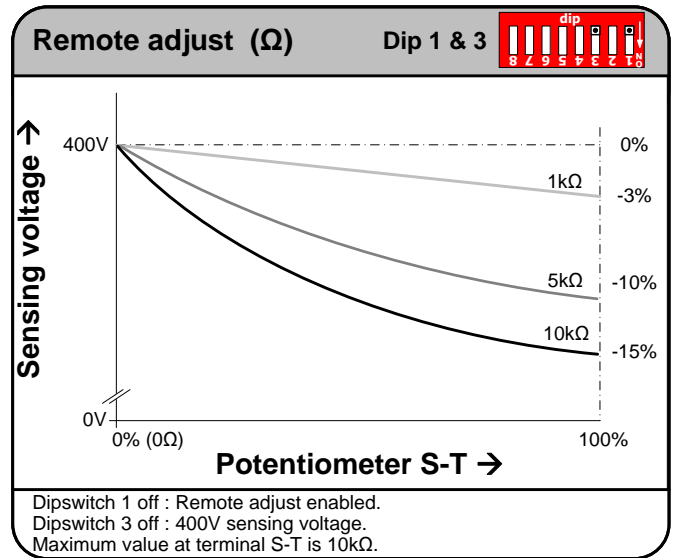
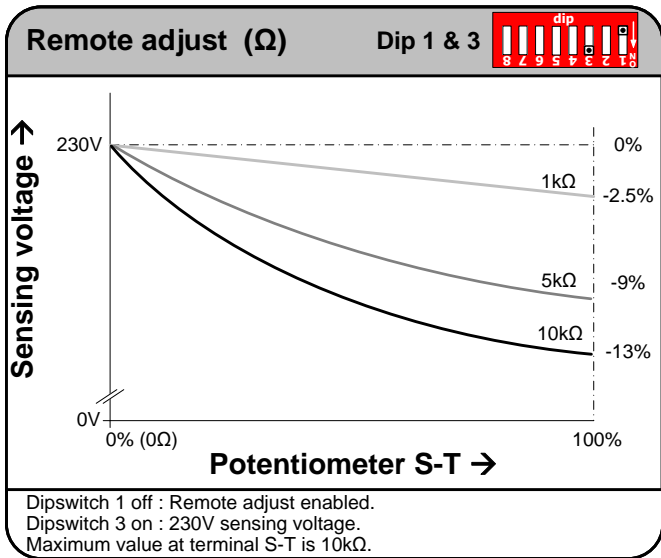

# MODES OF CONTROL III

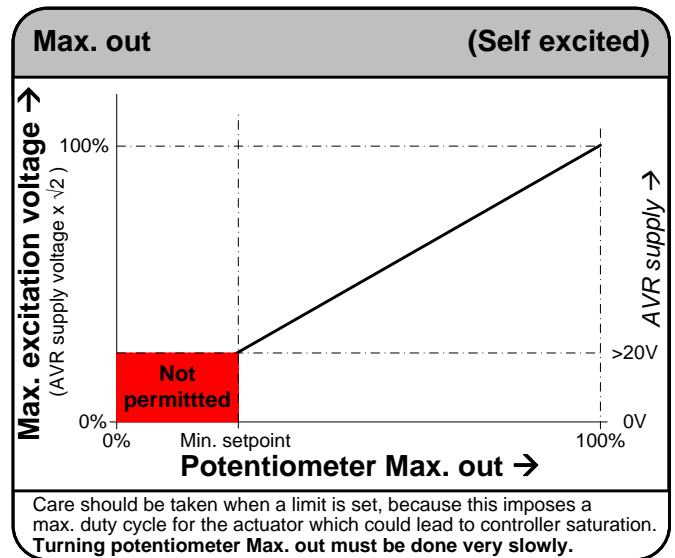
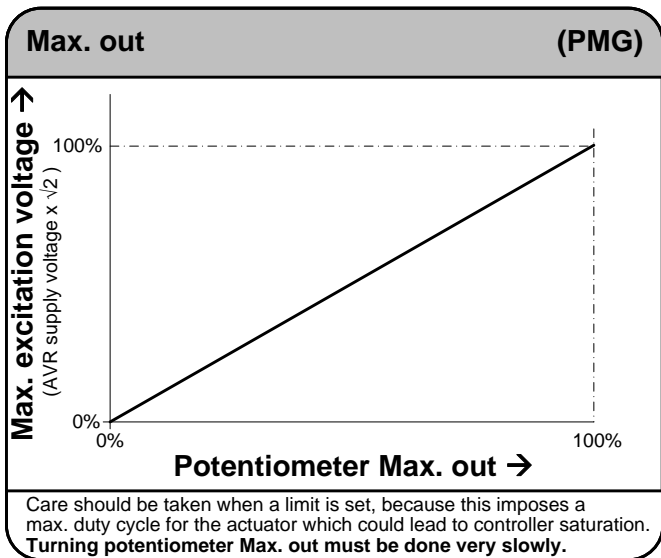
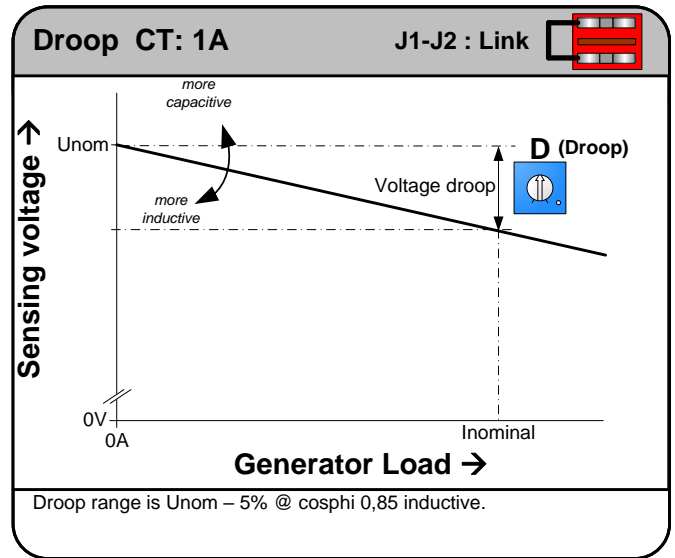
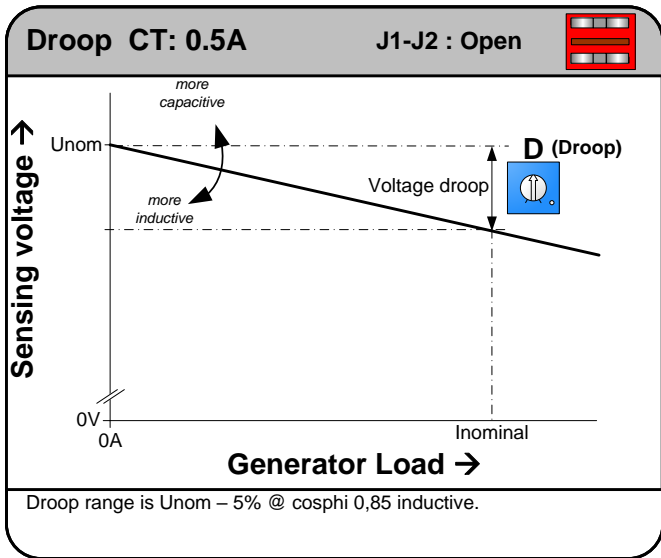

# COMMISSIONING SET UP

## Underspeed commissioning set up

**Start** (AVR Active / Generator running !)

Underspeed protection

Nominal speed

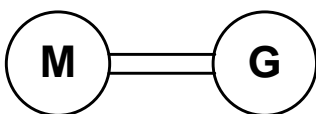

Threshold underspeed

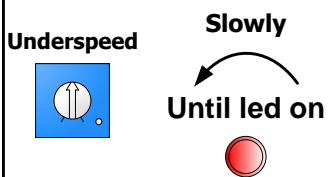

Indication setpoints



Setpoint underspeed

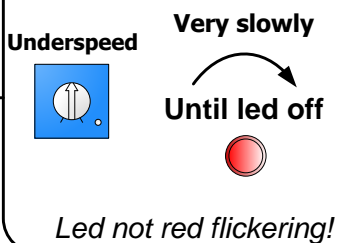



Note:

*It is recommended to turn the potentiometer a little further clockwise, to allow for short frequency dips.*

**Done**

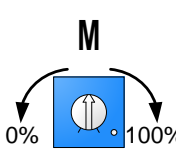
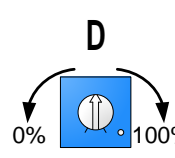
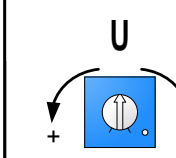
# QUICK REFERENCE I

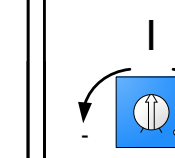
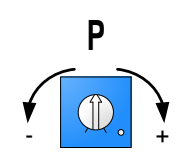
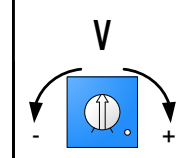
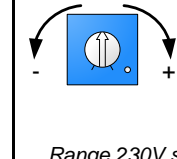
<b>Max. out</b>  <i>(Page 8)</i>	<b>Droop</b>  <i>(Page 8)</i>	<b>Underspeed</b>  Trip @ Higher - RPM - Lower +/- 62Hz +/- 27Hz  <b>Underspeed</b> <i>(Page 6)</i>	<b>Stability</b>  <b>I-action</b> <i>(Integral time)</i>  <b>P-action</b> <i>(Proportional gain)</i> <i>(Page 6)</i>	<b>Voltage</b>  <b>Coarse</b>  <b>Fine</b> Range 230V sensing +/- 185 .. 290V Range 400V sensing +/- 315 .. 505V
---	--	--	---	--

**Minimum Rfield**

## Formula

Minimum field resistance

$$\text{Field resistance } (\Omega) \geq \frac{\text{Supply input} \times \sqrt{2} \text{ (V}_{DC})}{40}$$

---

**AVR field current.**  
 Max. rating: Intermittent 17A < 10s.  
 Max. rating: Field forcing 20A < 1s.

**Factory settings**

Sensing voltage	: 400V
Underspeed frequency	: 45Hz
Underspeed slope	: Trip slope
Droop	: 100%
Stability P-action	: 50%
Stability I-action	: 50 %
Max. out	: 100 %
Dipswitch 1	: On
Dipswitch 2	: Off
Dipswitch 3	: Off
Dipswitch 4	: On
Dipswitch 5	: Off
Dipswitch 6	: Off
Dipswitch 7	: Off
Dipswitch 8	: Off

Link: J3-J4, EX-EX

**AFD Mode**

**Do not place or remove link!**

*Inputs are for EMRI AFD.*

AFD is an option unit  
for dual AVR applications.

*For more information  
see manual AFD.*

**Dipswitch** *(Page 5..8)*

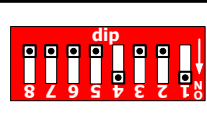

DIP	Off	On
1	Remote adjust enabled.	S-T internally shorted.
2	Phase loss protection disabled.	Phase loss protection enabled.
3	400V sensing voltage.	230V sensing voltage.
4	Underspeed trip disabled.	Underspeed trip enabled.
5	Underspeed F/V curve disabled.	Underspeed F/V curve enabled.
6	Buildup speed 2 sec.	Buildup speed 5 sec.
7	Normal Integral time.	Increased Integral time.
8	Underspeed voltage level +/- 27.5% of Unom.	Underspeed voltage level +/- 17.5% of Unom.

# QUICK REFERENCE II

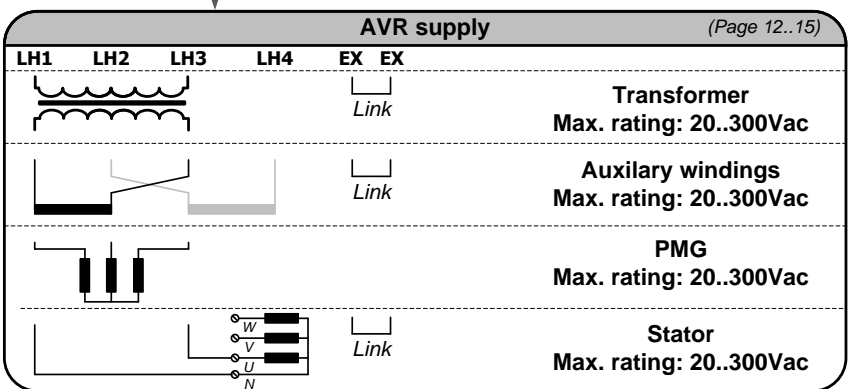
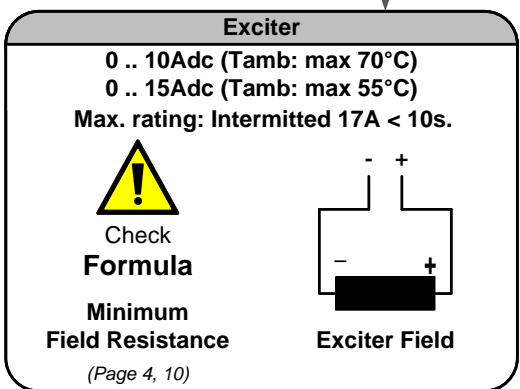
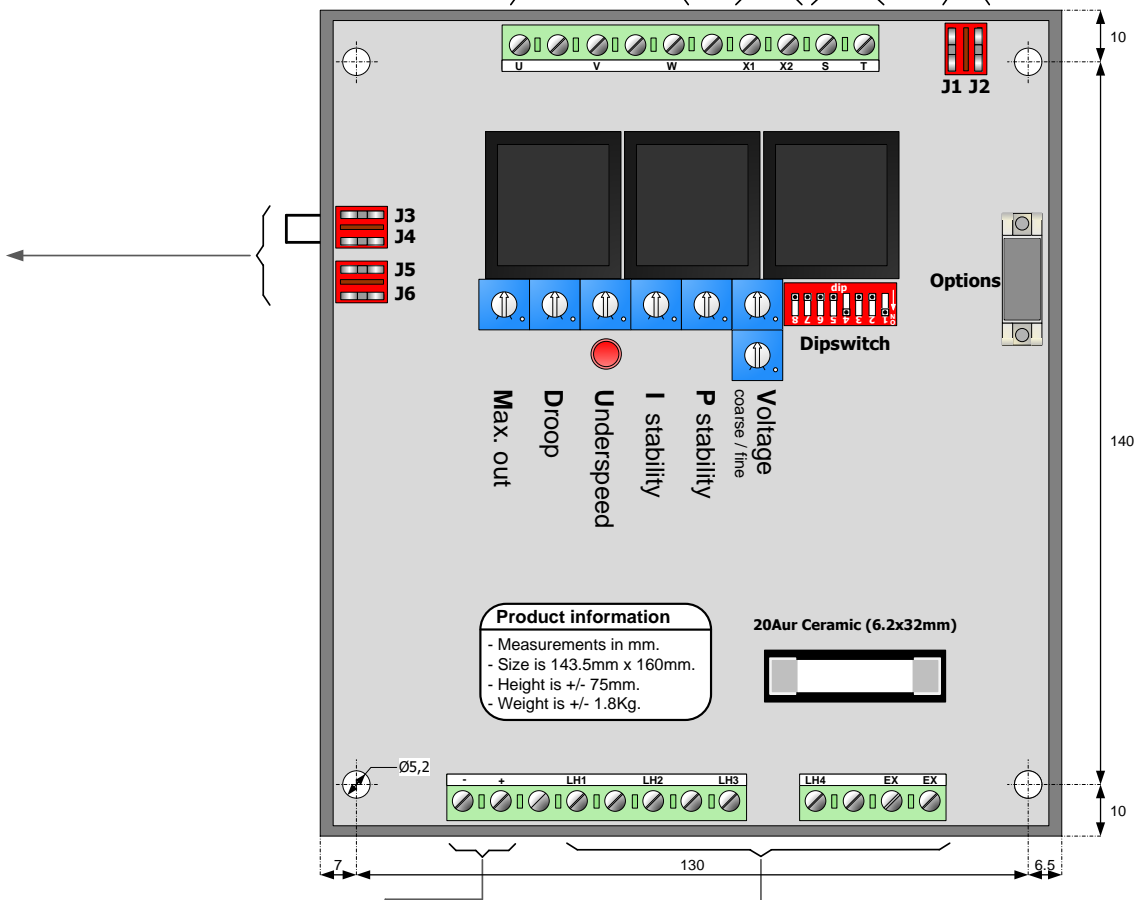
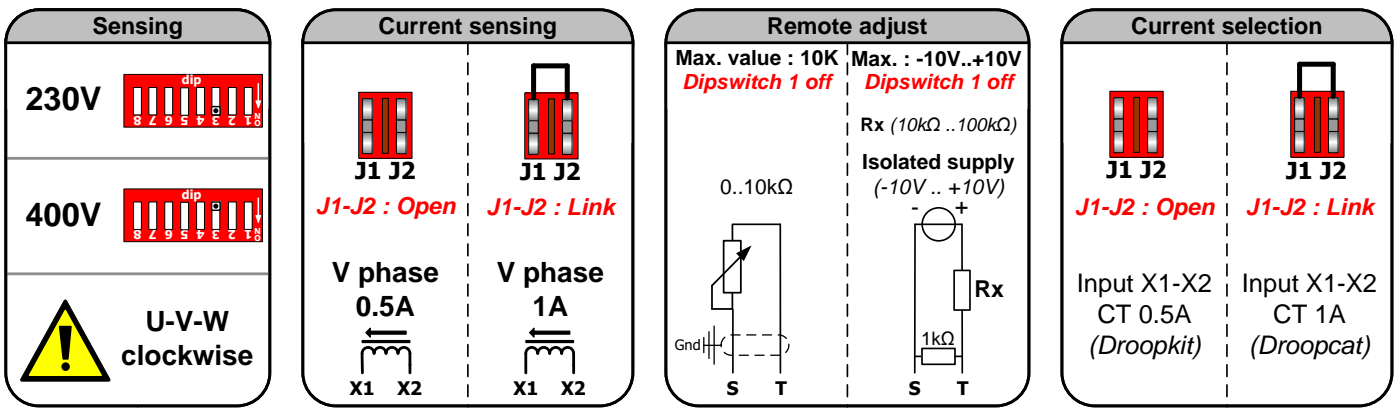

# WIRING DIAGRAM I

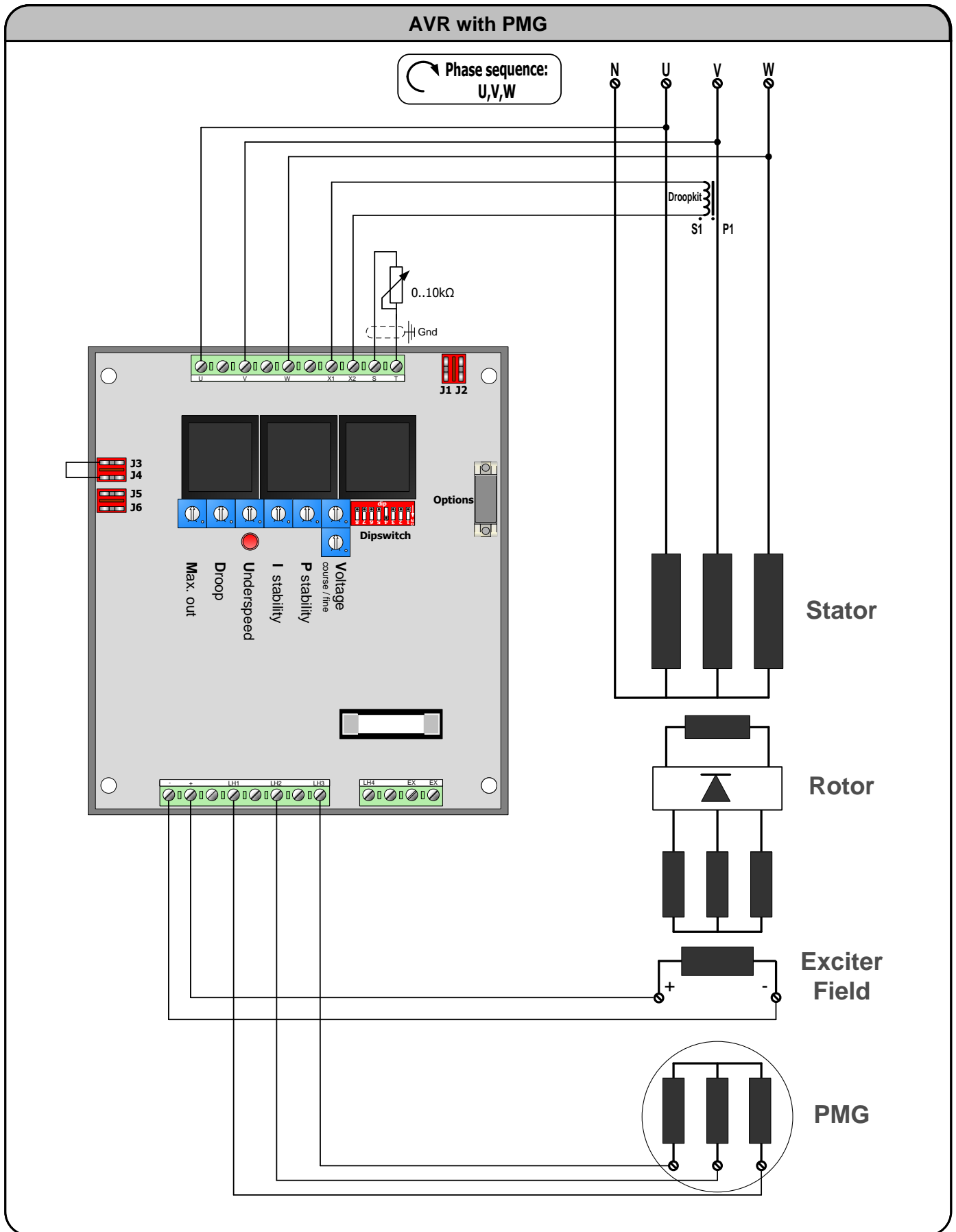

# WIRING DIAGRAM II

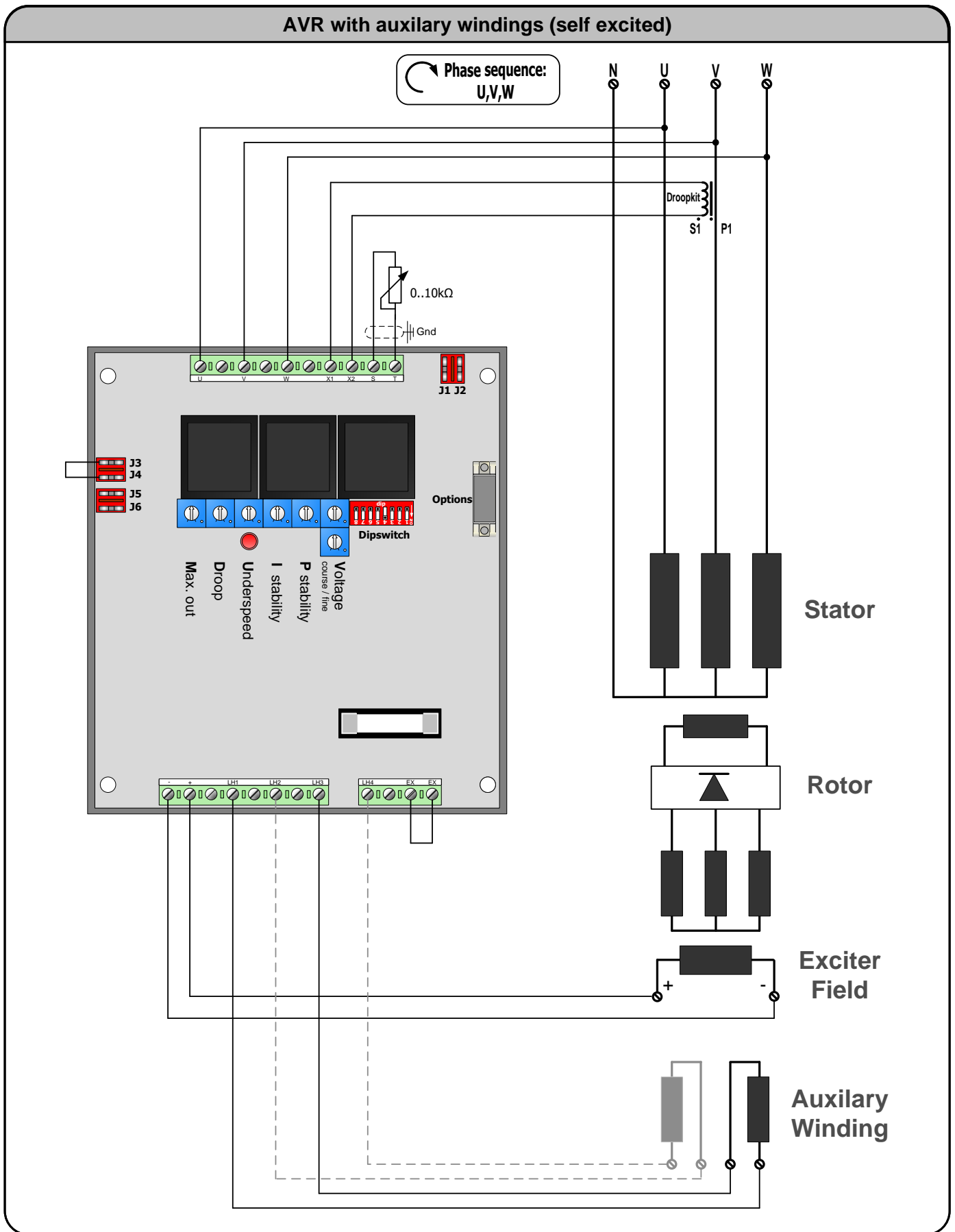

# WIRING DIAGRAM III

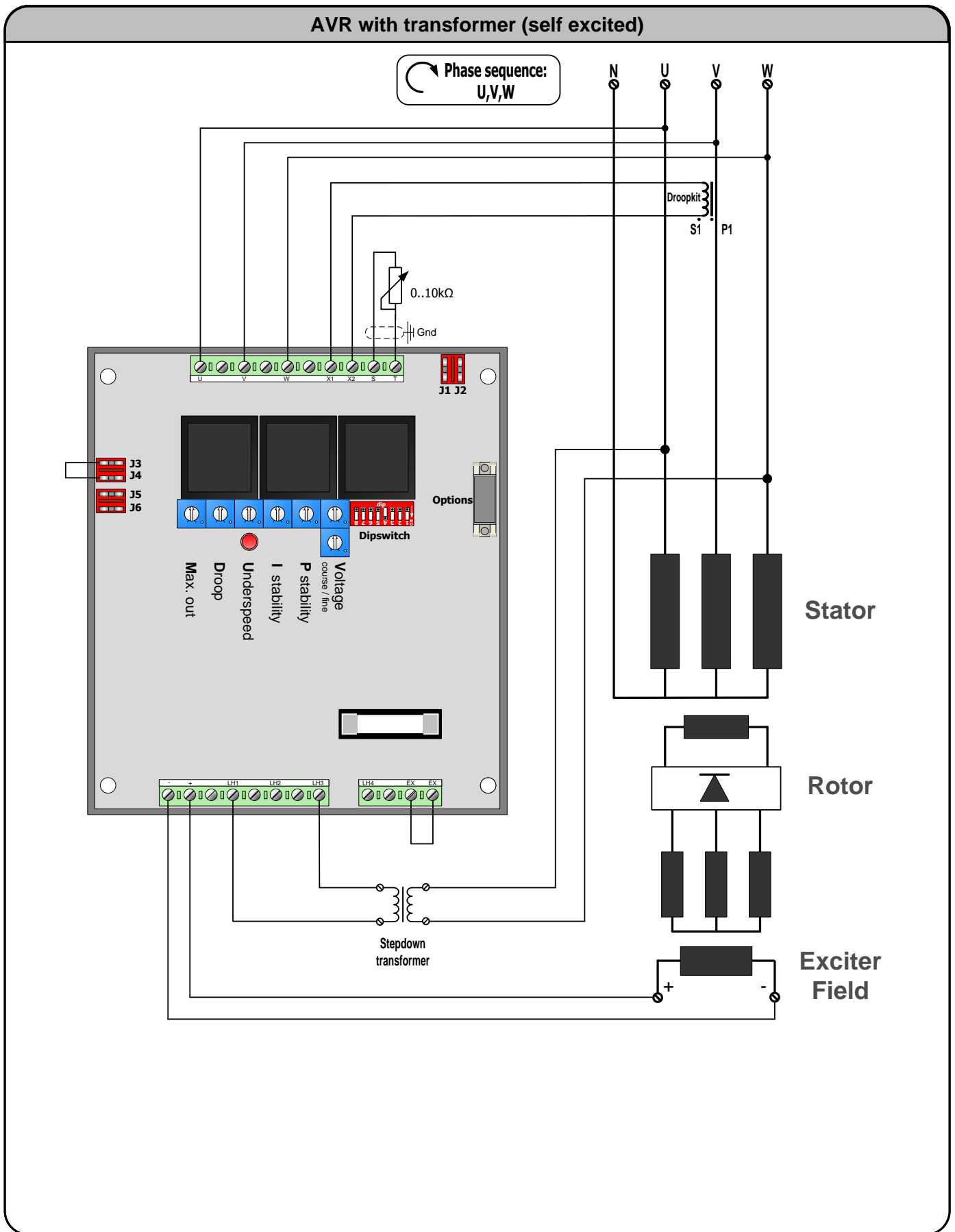

# WIRING DIAGRAM IV

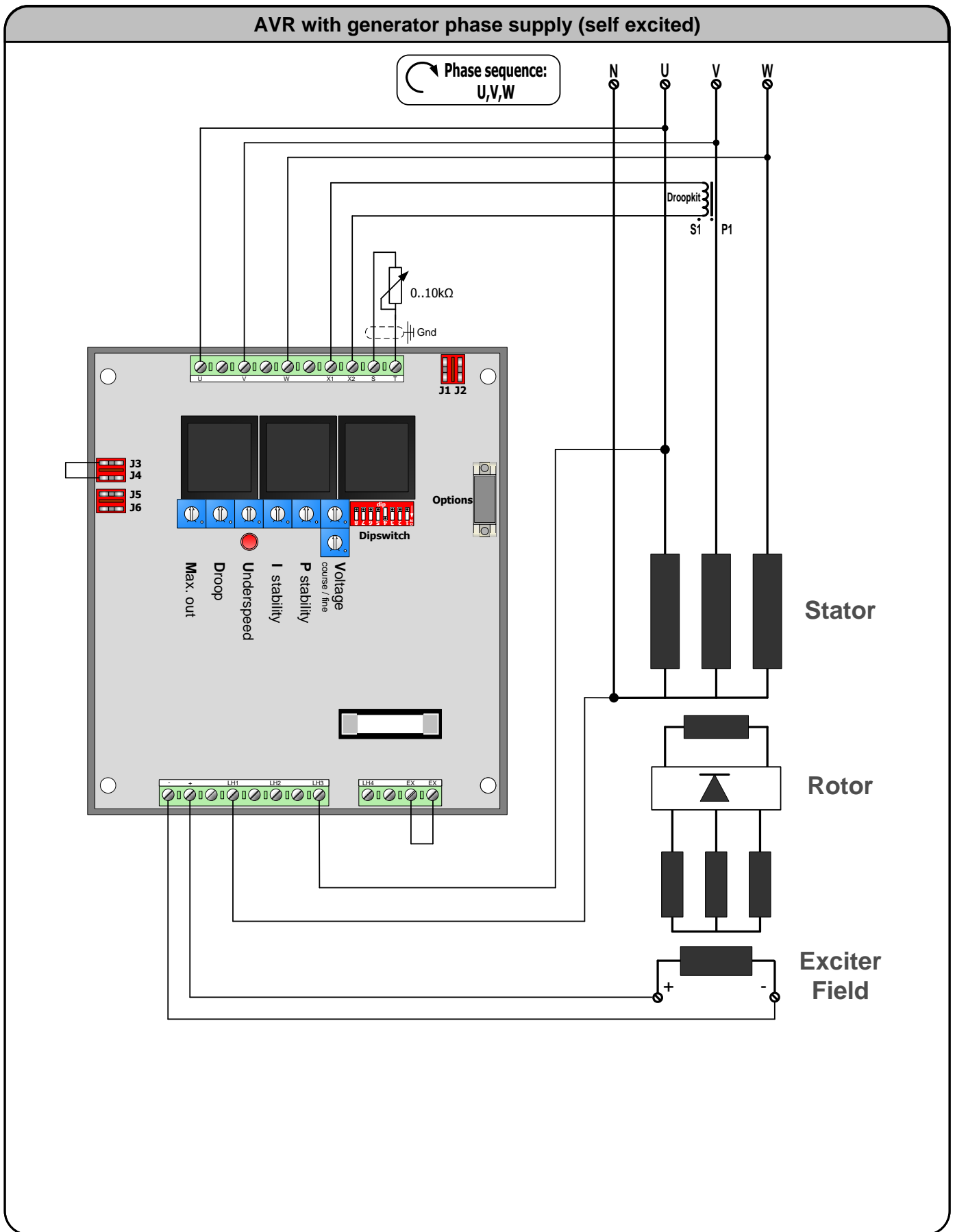

# TIPS AND SUGGESTIONS I

## Precautions for large, slow running generators

In general large (>1000kVA), slow running (<900RPM) generators tend to have more inductive exciter field windings. When the LX10.2 is used to control such a generator, the switched excitation current in combination with the increased inductivity can cause voltage spikes on the field excitation output. This can cause excessive AVR heating and damage to the AVR's output stage. To reduce voltage spikes it is recommended to fit RC-snubber in parallel and as close as possible to the exciter field.

## Generator insulation- / polarization index test

As a rule of thumb the testing voltage used during an insulation test is two times the nominal voltage of the winding under test. This exceeds the AVR ratings and may cause permanent damage to the AVR. Therefore the AVR must be disconnected completely from the generator. When performing an insulation test on the generator rotor disconnect the rotating rectifiers and any other components from the windings under test. This will prevent damage should the testing voltage exceed the rectifiers blocking voltage.

## Field flashing

In case of a self excited generator it could be that the residual voltage level is too low to build up. Causes for a low residual voltage can be a prolonged period of stand still, excessive heating or mechanical shock and vibration.

To restore the residual voltage the generator can be manual field flashed. In order to perform this safely the AVR must be completely disconnected from the generator. Next a potential free voltage (e.g. a 9V battery block) source is connected to the exciter field of the generator, while it's rotating. This will cause the generator voltage to rise and restore the residual voltage level.

If the residual voltage of the generator is permanently low, an automatic field flash unit can be used or a potential free voltage source which is automatically switched off when the generator voltage is within normal range. The generator voltage should not exceed nominal voltage when field flash is active, to prevent damage to the AVR. When using "Automatic field flash" there should always be a rectifier bridge in the output of the source/unit.

# TIPS AND SUGGESTIONS I I

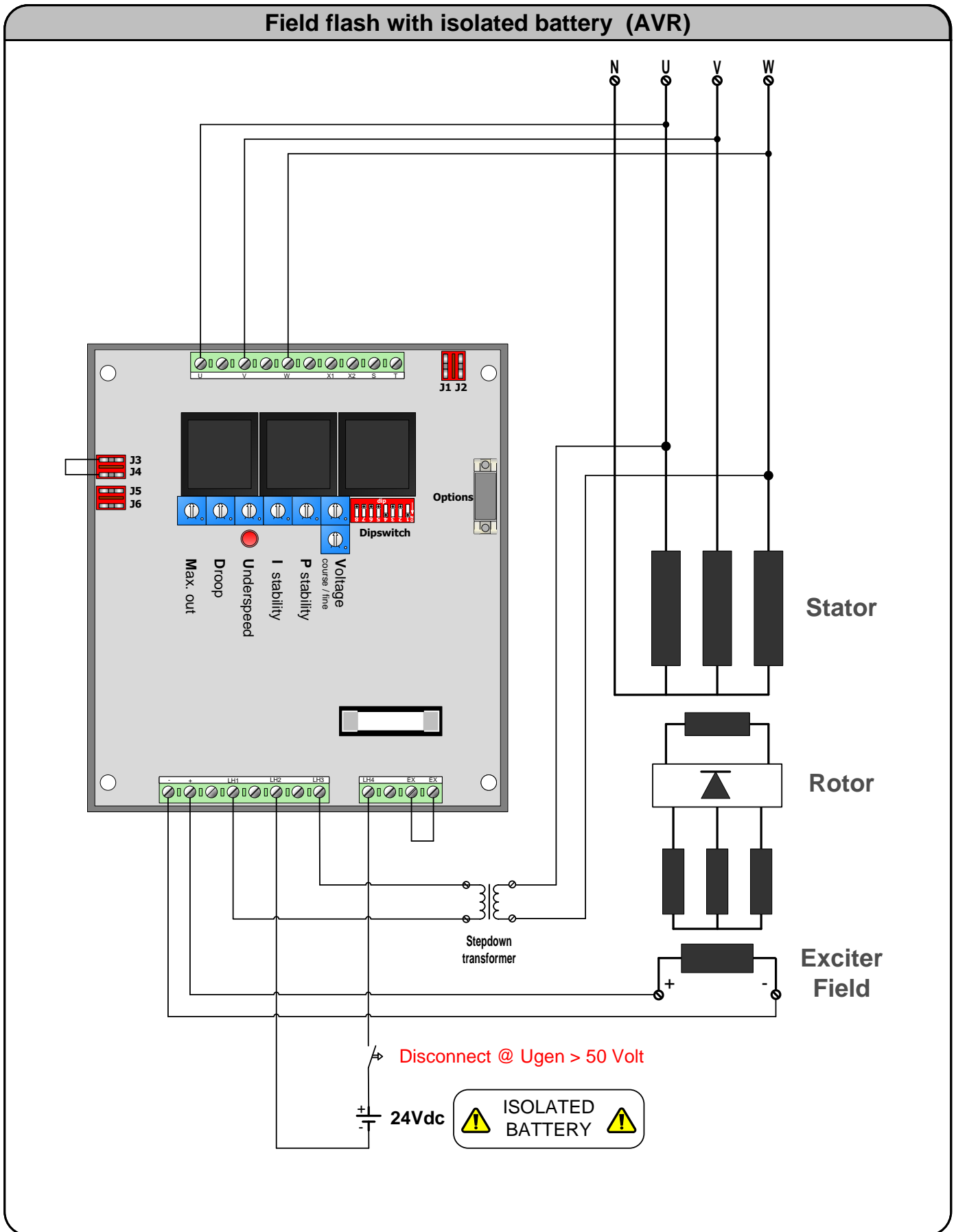

# TIPS AND SUGGESTIONS I I I

## Field flash with isolated battery (Exciter field)

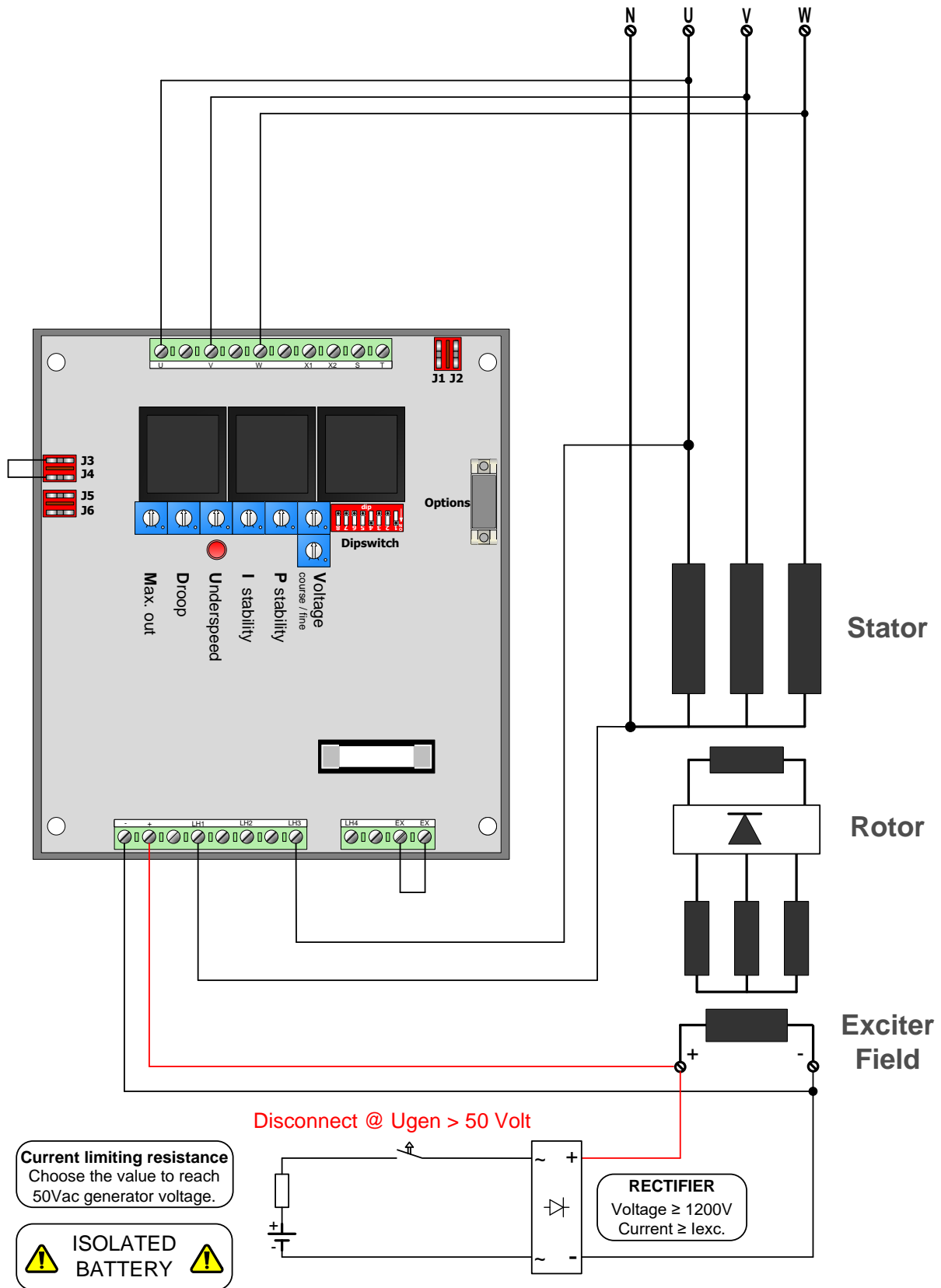

# GENERAL INSTALLATION INFORMATION

## Absolute Maximum Ratings

- The Absolute Maximum Ratings are those limits for the device that, if exceeded, will likely damage the device. Exceeding the absolute maximum ratings voids any warranty and/or guarantee.

## Mounting

Mounting of the product should be done in such a way that:

- the absolute maximum ambient temperature rating of the product will never be exceeded.
- maximum cooling (direction of cooling ribs and direction of airflow) is achieved.
- Mounting no humid air can flow through the product or condensation occurs.
- dust or other materials or residue will not remain in or on the product.
- the maximum vibration is not exceeded.
- personal contact with persons is impossible.

## Wiring

- Diameter size of the wiring should be enough to carry the expected current. Wire insulation should be enough to withstand the expected operating voltages and temperatures.
- To improve EMC emission and immunity, care should be taken for the lay out of the wiring. This in respect to all wiring in the installation.
- Keep current carrying wires as short as possible.
- Keep wires carrying a total sum of zero Ampere close to each other, or in one single cable, E.g. U, V, W, or X (+) and XX (-), or Phase and neutral, or S and T.
- Avoid current carrying conductors next to sensing or control wiring. Especially current controlled by SCR's or PWM controlled transistors.
- If sensitive sensing signal cables need to be laid across distance along other cabling, shielded cable is preferred. Keep the shield as long as possible and the wiring outside the shield as short as possible. Do not solder or shrink the shield to a regular wire. Connect the original shield to ground at one side with an as large as possible contact surface.

## Additional installation information

- When the product is supplied by means of a transformer, it should never be an auto-transformer. Auto-transformers react as voltage sweep up coil and may cause high voltage peaks.
- Standard fit capacitors or over-voltage suppressers across X (+) and XX (-), or exciter field terminals inside the generator should be removed.
- When the product is supplied by means of a transformer, it should be able to carry at least the maximum expected current. Advisable is, to have a transformer which can carry twice the maximum expected current. Inductive loads make voltage sags and peeks into the secondary voltage of a transformer, from which the device may malfunction.
- It is not recommended to apply switches in dc outputs. It is preferred to use switches in the ac supply inputs of devices. In case it is unavoidable to have switches in the dc output of a device, action must be taken to avoid over voltage damage to the device due to contact arcing. Use a voltage suppressor across the output.
- It is not recommended to apply switches or fuses in the sensing lines. Defects can cause high voltage situations due to over-excitation.
- When using a step down transformer in medium or high voltage generators, the transformer should be three phase (if three phase sensing), and the transformer should be suitable for acting as a sensing transformer. If the transformer is unloaded, connect a resistor to avoid voltage waveform distortion.
- The phase relation from the generator to the AVR is important. Also when voltage transformers and/ or current transformers are installed.
- When using a step down or insulation transformer in the droop circuit, phase relation from the generator to the AVR is important.
- CT's wiring, connected to the AVR should never be grounded.
- Always disconnect electronic products, circuits and people before checking the insulation resistance (Megger check).
- Due to differences in generators impedance's, EMC behavior is not predictable. Therefore the commissioner / installer should be aware of proper and correct installation.
- Large, highly inductive, exciter stator windings can cause destructive high voltage peaks. Adding a resistor from 10 to 20 times the exciter stator field resistance reduces voltage spikes. If necessary filter can be fitted additionally. (e.g. snubber, RC-network)
- Upon problems during commissioning, faulty behavior or defects in the generator, consult the fault finding manual at our web site
- Some advises may be overdone or seem extraordinary, but since the electrical rules are the same everywhere, these advises are given.

# CONTACT

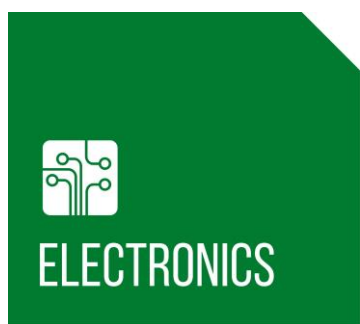

EMRI Electronics B.V.  
Morsestraat 10  
6716 AH, Ede, Netherlands  
Tel: +31 (0)318 620 427  
Website: [www.emri.nl](http://www.emri.nl)  
E-mail: [info@emri.nl](mailto:info@emri.nl)

**Manufacturer**



**CANARY ISLANDS**, Las Palmas  
**Zamakona Yards**  
Tel: +34 928467521  
Fax: +34 928461233  
Website: [www.zamakonayards.com/](http://www.zamakonayards.com/)  
E-mail: [ibetancor@zamakonayards.com](mailto:ibetancor@zamakonayards.com)

**CHILE**, Santiago  
**Lucio Vicencio y CIA.LTDA**  
Tel: +1-281-334-2904  
Fax: +1-832-221-5642  
Website: [www.luciovicencio.cl](http://www.luciovicencio.cl)  
E-mail: [luciovincencioltda@gmail.com](mailto:luciovincencioltda@gmail.com)

**GREECE**, Piraeus  
**Stavros Kassidiaris S.A.**  
Tel: +30 210 4636000  
Fax: +30 210 4624471  
Website: [www.kassidiaris.gr](http://www.kassidiaris.gr)  
E-mail: [info@kassidiaris.gr](mailto:info@kassidiaris.gr)

**ICELAND**, Hafnarfjordur  
**Rafeining ehf**  
Tel: +354 565 3049  
Fax: +354 565 3048  
Website: [www.rafeining.is](http://www.rafeining.is)  
E-mail: [rafeining@rafeining.is](mailto:rafeining@rafeining.is)

**INDIA**, Faridabad  
**Power Solutions**  
Tel: +91 9868907903  
Fax: +91 129 2431216  
Website: [www.psolindia.com](http://www.psolindia.com)  
E-mail: [ramesh.powersolutions@gmail.com](mailto:ramesh.powersolutions@gmail.com)

**NORWAY**, Bergen  
**Frydenbø Electric A/S**  
Tel: +47 55 34 91 00  
Fax: +47 55 34 91 10  
Website: [www.frydenbo.no](http://www.frydenbo.no)  
E-mail: [firma.fel@frydenboe.no](mailto:firma.fel@frydenboe.no)

**POLAND**, Gdynia  
**An-Elec Sp. z o.o.**  
Tel: +48 58 668 44 00  
Fax: +48 58 668 44 66  
Website: <http://an-elec.pl>  
E-mail: [info@an-elec.pl](mailto:info@an-elec.pl)

**POLAND**, Szczecin  
**MARCONTREL**  
Tel: +48 91 4 888 474  
Fax: +48 91 4 888 475  
Website: [www.marcontrel.com](http://www.marcontrel.com)  
E-mail: [emri@marcontrel.com](mailto:emri@marcontrel.com)

**POLAND**, Szczecin-Mierzyn  
**Marel Serwis**  
Tel: +48 91 48 58 388  
Fax: +48 91 48 79 948  
Website: [www.marel.szczecin.pl](http://www.marel.szczecin.pl)  
E-mail: [handel@marel.szczecin.pl](mailto:handel@marel.szczecin.pl)

**REPUBLIC OF PANAMA**, Panama  
**PASRAS S.A.**  
Tel: +507 3140095  
Fax: +507 3140094  
Website: [www.pasras.com](http://www.pasras.com)  
E-mail: [info@pasras.com](mailto:info@pasras.com)

**ROMANIA**, Constanta  
**SAMTEC SRL**  
Tel: +40 241 517 047  
Fax: +40 241 517 047  
Website: [www.samtec.ro](http://www.samtec.ro)  
E-mail: [samtec\\_srl@yahoo.com](mailto:samtec_srl@yahoo.com)

**SINGAPORE**, Singapore  
**Cyclelect Electrical Engineering**  
Tel: +65 6868 6013  
Fax: +65 6863 6260  
Website: [www.cyclelect.com.sg](http://www.cyclelect.com.sg)  
E-mail: [heng.p@cyclelect.com.sg](mailto:heng.p@cyclelect.com.sg)

**SOUTH AFRICA**, Roodepoort  
**Yneldo Electronics**  
Tel: +27(0)117637053  
Fax: +27(0)117634212  
Website: [www.yneldo.com](http://www.yneldo.com)  
E-mail: [yneldo@yneldo.com](mailto:yneldo@yneldo.com)

**SWEDEN**, Kungälv  
**Elektrisk Drivteknik EDT AB**  
Tel: +46-705-28 20 60  
Tel: +46-709-50 47 90  
Website: [www.edtab.se](http://www.edtab.se)  
E-mail: [info@edtab.se](mailto:info@edtab.se)

**THAILAND**, Bang Lamung  
**Semtec Maritime/Genetech Co.Ltd**  
Tel: +66 38301262  
Fax: +1-832-221-5642  
Website: [semtecmaritime.com/](http://semtecmaritime.com/)  
Email: [info@semtecmaritime.com](mailto:info@semtecmaritime.com)

**TURKEY**, Izmir  
**INTEGRAL**  
Tel: +90 (555) 211 55 75  
Email: [ozgur@integralguc.com](mailto:ozgur@integralguc.com)

**UNITED ARAB EMIRATES**, Sharjah  
**KDU Technical Services**  
Tel: +971-6-5575480  
Fax: +971-6-5575490  
Website: [www.kdutech.ae](http://www.kdutech.ae)  
E-mail: [kdutech@kdutech.ae](mailto:kdutech@kdutech.ae)

**UNITED KINGDOM**, Stockton on Tees  
**MJR Controls**  
Tel: +44 1642 762 151  
Fax: +44 1642 762 502  
Website: [www.mjrcontrols.com](http://www.mjrcontrols.com)  
Email: [chris.milner@mjrcontrols.com](mailto:chris.milner@mjrcontrols.com)

**UNITED KINGDOM**, Cheadle Hulme  
**TGS Total Generator Solutions Ltd**  
Tel: +44161 8188720  
Fax: +447754677963  
Website: <http://totalgeneratorsolutions.com>  
Email: [sales@totalgeneratorsolutions.com](mailto:sales@totalgeneratorsolutions.com)

**UNITED STATES**, Kemah - Texas  
**Ramtec Marine Systems LLC**  
Tel: +1-281-334-2904  
Fax: +1-832-221-5642  
Website: [www.ramtec-marine.com](http://www.ramtec-marine.com)  
Email: [waling@ramtec-marine.com](mailto:waling@ramtec-marine.com)