



KASR10

Voltage regulator for generators

Instruction Manual V2.4

Product version V1.1.0.0

EMRI ELECTRONICS
POWER IN CONTROL



WARNINGS AND COMMISSIONING INFORMATION



HAZARDOUS VOLTAGES.



DO NOT OPERATE WHEN NOT FAMILIAR WITH GENERATORS.

- **Check the isolation of the generator windings before installation.**
Poor isolation will cause damage to the AVR and dangerous situations for persons.
- The system should not be installed, operated, serviced or modified except by qualified personnel who understand the danger of electric shock hazards and have read and understood the user instructions.
- Never work on a LIVE generator. Unless there is another person present who can switch off the power supply or stop the engine.
- Dangerous voltages are present at the voltage regulator board. Accidental contact with live conductors could result in serious electrical shock or electrocution.
- Disconnect the power source before making repairs, connecting test instruments, or removing or making connections to the voltage regulator or generator.
- Defects in the generator or AVR may cause consequential loss. Precautions must be taken to prevent this from occurring.
- The unit should be installed with respect to the environmental specifications as well as the rules mentioned in the General installation information.
- For safety reasons the voltage level potentiometers are best turned completely counter clockwise in order to start at the lowest possible voltage.
- Never change the dipswitch settings during operation.

REVISION HISTORY

Product	Version		Change
	Hardware	Manual	
V1.0	1.0	2.3	<i>First release.</i>
V1.1	1.0	2.4	<i>New manual layout.</i>

The table provides a historical summary of the changes made to the AVR.
Revisions are listed in chronological order.

The manual does not cover all technical details of the product. Specifications may be modified by the manufacturer without notice. For further information, the manufacturer should be contacted.

TABLE OF CONTENTS

General description	3
Absolute maximum ratings	4
Tips and Suggestions	5
Modes of control	8
Quick reference	9
Commissioning set up	10
Wiring diagrams	11
General installation information	15
Contact	16

GENERAL DESCRIPTION

The KASR10 is an universal AVR, suitable for single and three phase synchronous generators up to approximately 200kVA.

The KASR10 AVR is not suitable for parallel operation of generators.

When parallel operation must be controlled, the **KASR20** with reactive current sharing is available.

When the system tends to instability, the KASR20 with adjustable Proportional and Integral regulator function is available. Maximum stability can be obtained by using a three phase sensing AVR with IGBT technology such as the EMRI **LX10.2**.

Installation, maintenance and adjustment don't require special application software.

The AVR is protected from the environment by a PUR coating.

ABSOLUTE MAXIMUM RATING

Symbol	Parameter	Condition	Min.	Max.	Unit
0V, 230V	Sensing & supply input	Minimum supply for self excitation	3.5	-	V _{AC}
	115Volt	50 – 60Hz.	-	130	V _{AC}
		50 – 60 Hz, Intermitted < 10s.	-	140	V _{AC}
230Volt	50 – 60Hz.	-	260	V _{AC}	
	50 – 60 Hz, Intermitted < 10s.	-	280	V _{AC}	
+, -	AVR field current	Intermitted < 1s. ^{(1) (3)}	-	10	A _{DC}
	AVR field voltage	DC % of supply voltage (RMS)	-	35	%DC
	Field resistance	^{(2) (3)}	4	-	Ω
T _{AMB}	Operating temperature	95% RHD non condensing ⁽¹⁾	0	+70	°C
T _{STG}	Storage temperature	95% RHD non condensing	-20	+85	°C
	Static control accuracy			1	%

⁽¹⁾ Always mount with heatsink fins aligned vertically and allow for sufficient airflow.

⁽²⁾ See formula for calculating minimum field resistance

⁽³⁾ See table below for safe operation area of the AVR.



$$\text{Field resistance } (\Omega) \geq \frac{\text{Supply input} \times 0.35 \text{ (V}_{\text{DC}})}{10}$$



Stresses above “Absolute Maximum Ratings” may cause permanent damage to the device. This is a stress rating only, the functional operation of the device or any other conditions indicated in the “operation area” of this specification is not implied. Exposure to maximum rating conditions for extended periods may affect device reliability and lifetime.

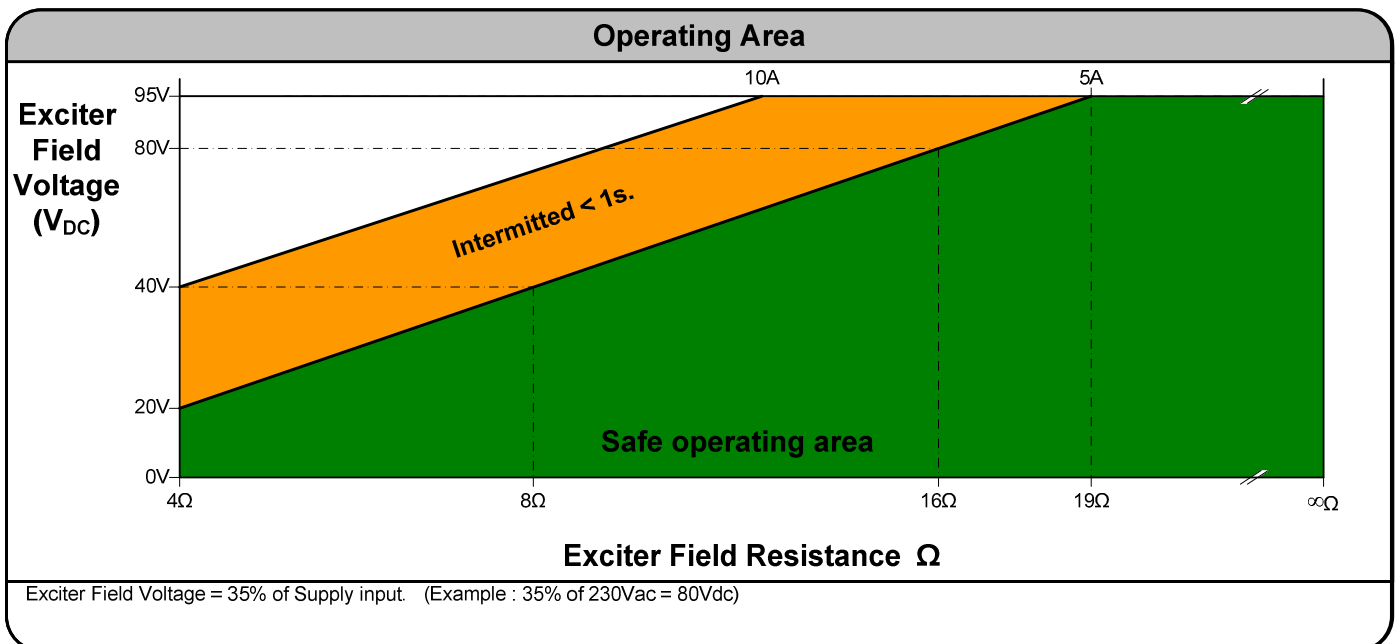

TIPS AND SUGGESTIONS I

Generator insulation- / polarization index test

As a rule of thumb the testing voltage used during an insulation test is two times the nominal voltage of the winding under test. This exceeds the AVR ratings and may cause permanent damage to the AVR. Therefore the AVR must be disconnected completely from the generator. When performing an insulation test on the generator rotor disconnect the rotating rectifiers and any other components from the windings under test. This will prevent damage should the testing voltage exceed the rectifiers blocking voltage.

Field flashing

In case of a self excited generator it could be that the residual voltage level is too low to build up. Causes for a low residual voltage can be a prolonged period of stand still, excessive heating or mechanical shock and vibration.

To restore the residual voltage the generator can be manual field flashed. In order to perform this safely the AVR must be completely disconnected from the generator. Next a potential free voltage (e.g. a 9V battery block) source is connected to the exciter field of the generator, while it's rotating. This will cause the generator voltage to rise and restore the residual voltage level.

If the residual voltage of the generator is permanently low, an automatic field flash unit can be used or a potential free voltage source which is automatically switched off when the generator voltage is within normal range. The generator voltage should not exceed nominal voltage when field flash is active, to prevent damage to the AVR. When using "Automatic field flash" there should always be a rectifier bridge in the output of the source/unit.

TIPS AND SUGGESTIONS I I

Field flash with isolated battery

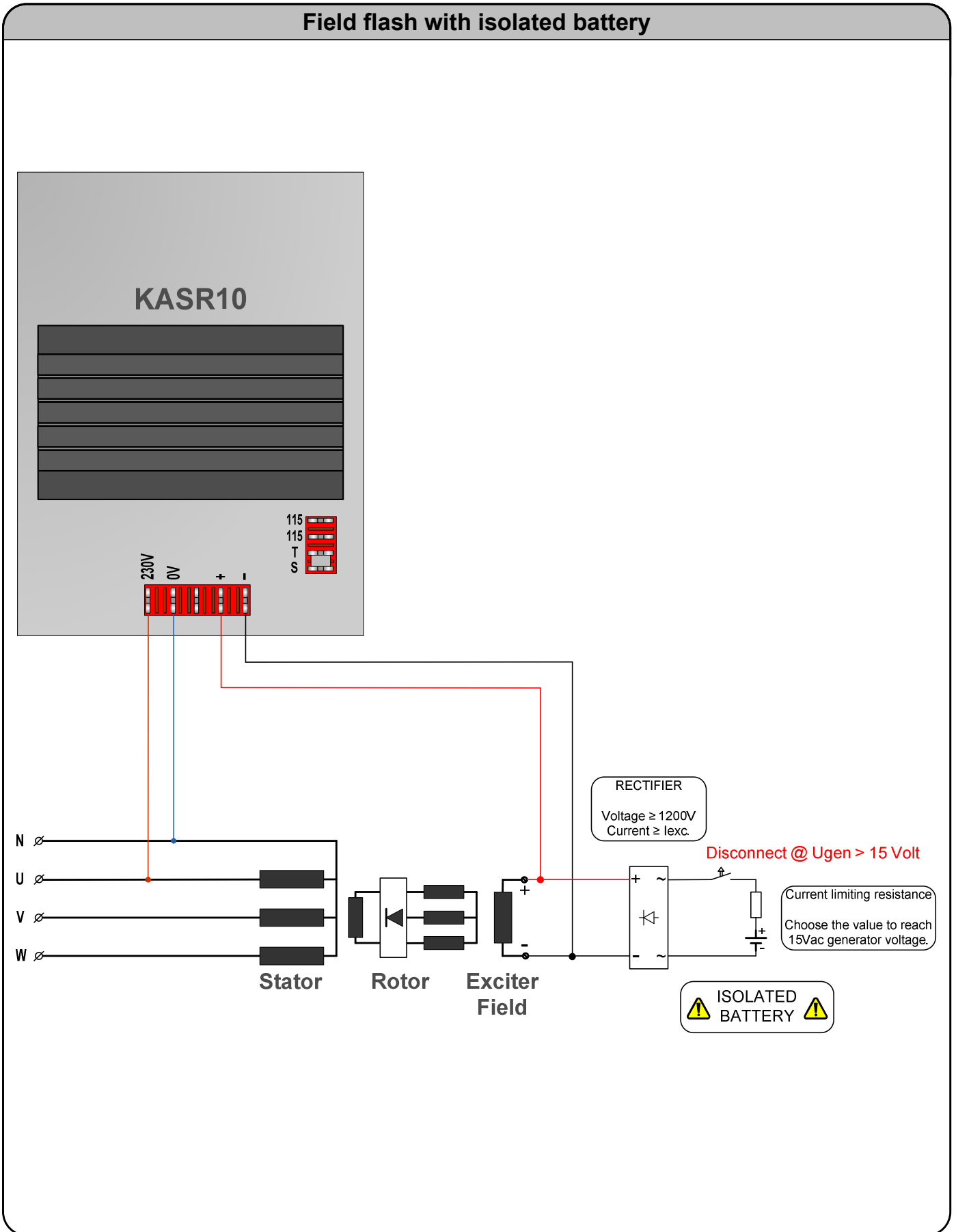

TIPS AND SUGGESTIONS I I I

Field flash with grounded battery

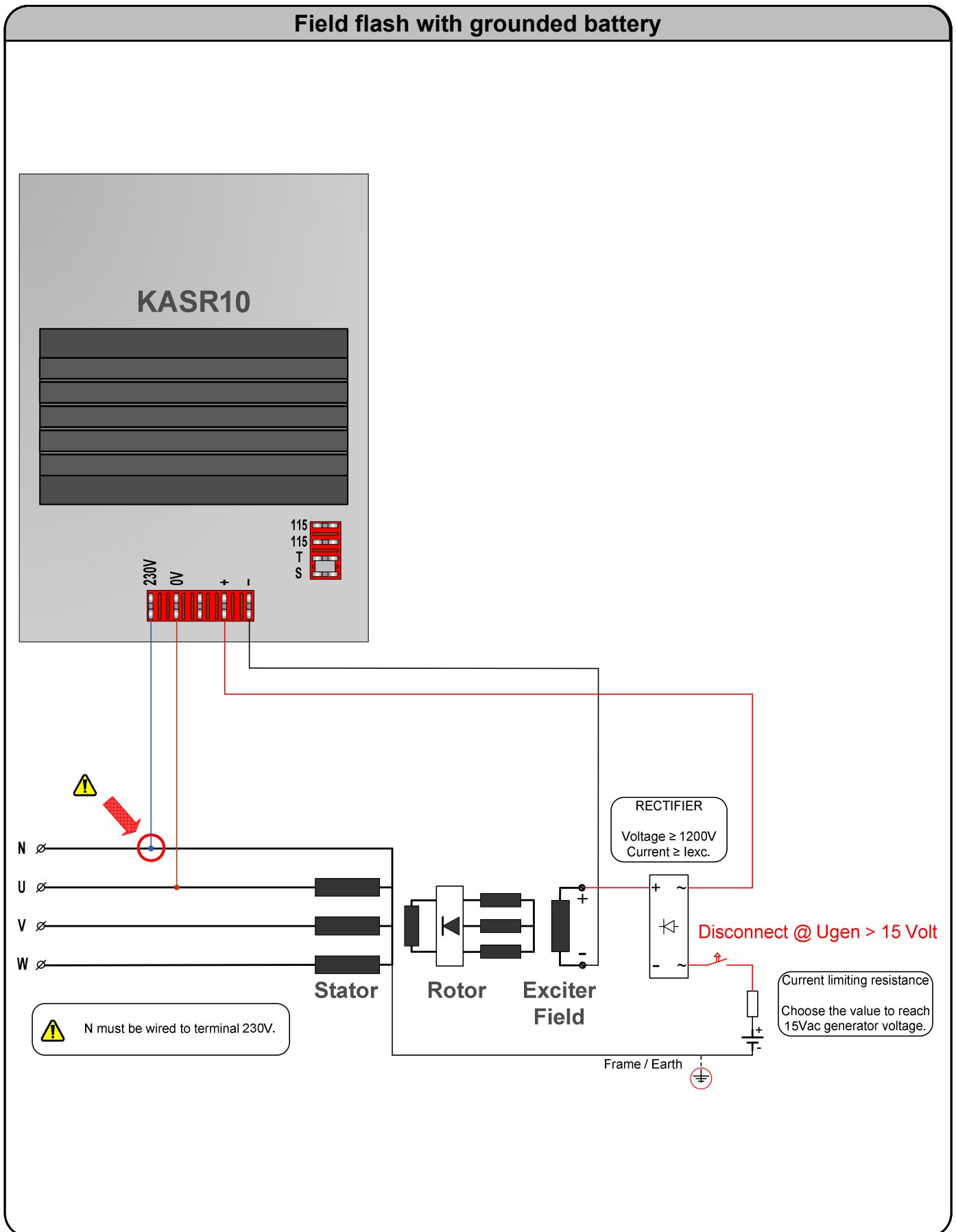

MODES OF CONTROL

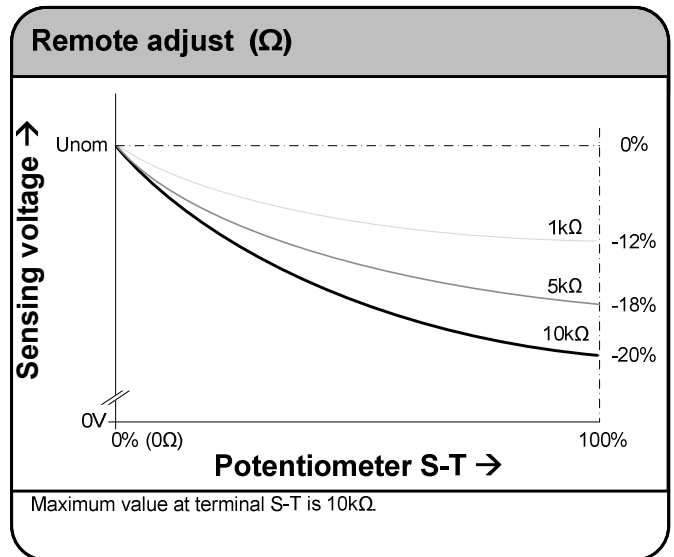
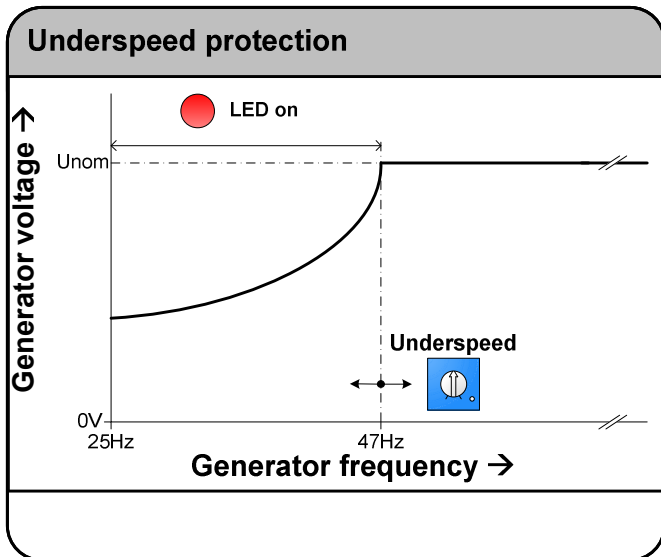
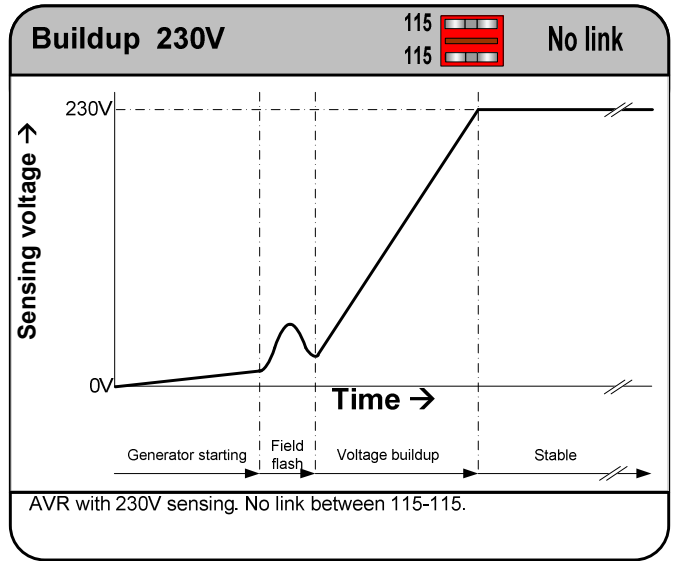
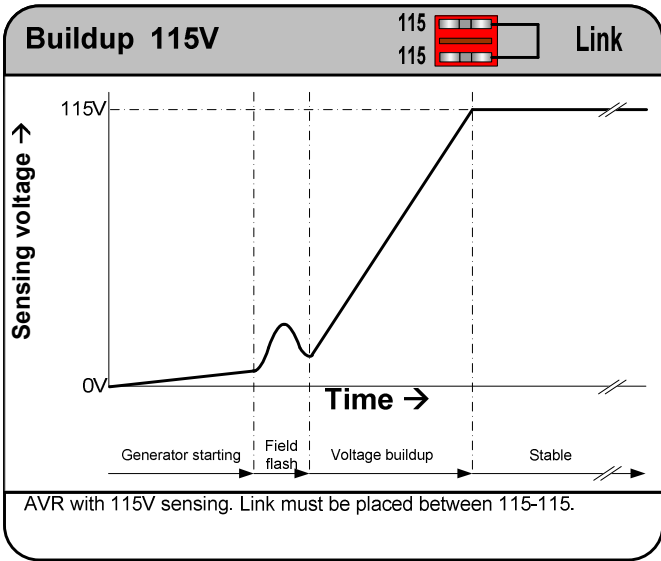

QUICK REFERENCE

Voltage



Range 115V sensing
+/- 80 .. 130V

Range 230V sensing
+/- 160 .. 260V

Stability



Decrease stability Increase stability

(Page 10)

Underspeed



Increase Hz setpoint Decrease Hz setpoint

Underspeed (Red LED)

(Page 8, 10)

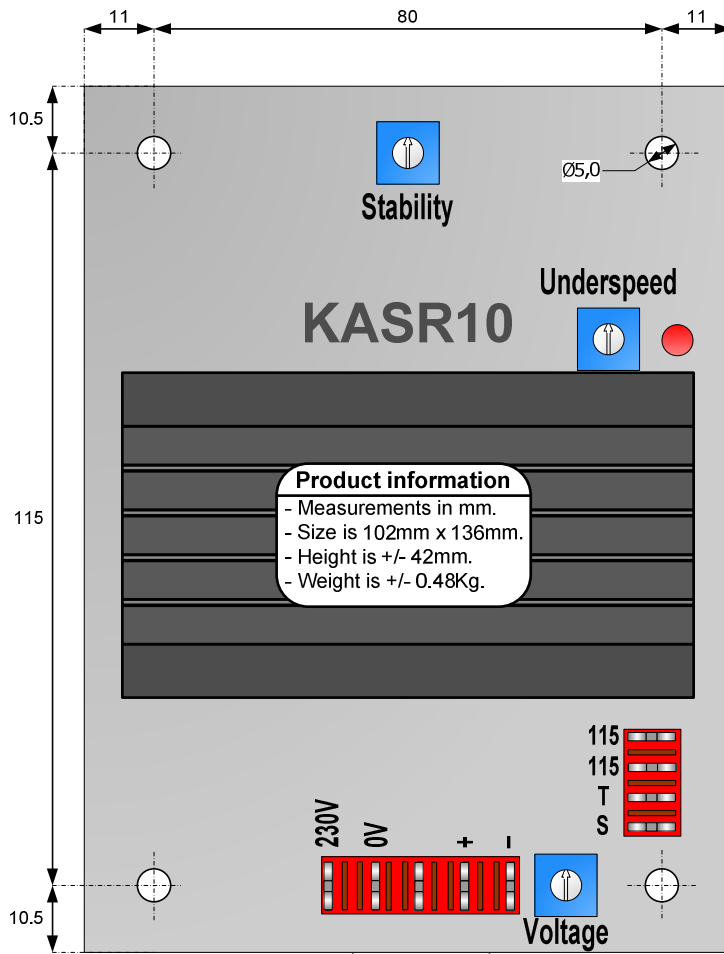

Factory settings

Voltage : 230V
Underspeed : 47Hz
Stability : 50%
S – T : Link
115 – 115 : No link

Voltage selection

115V Sensing

115 115  Link

230V Sensing

115 115  No link

Remote adjust
(No potentiometer)

T S  Link

Maximum value : 10K

T S  0..10kΩ

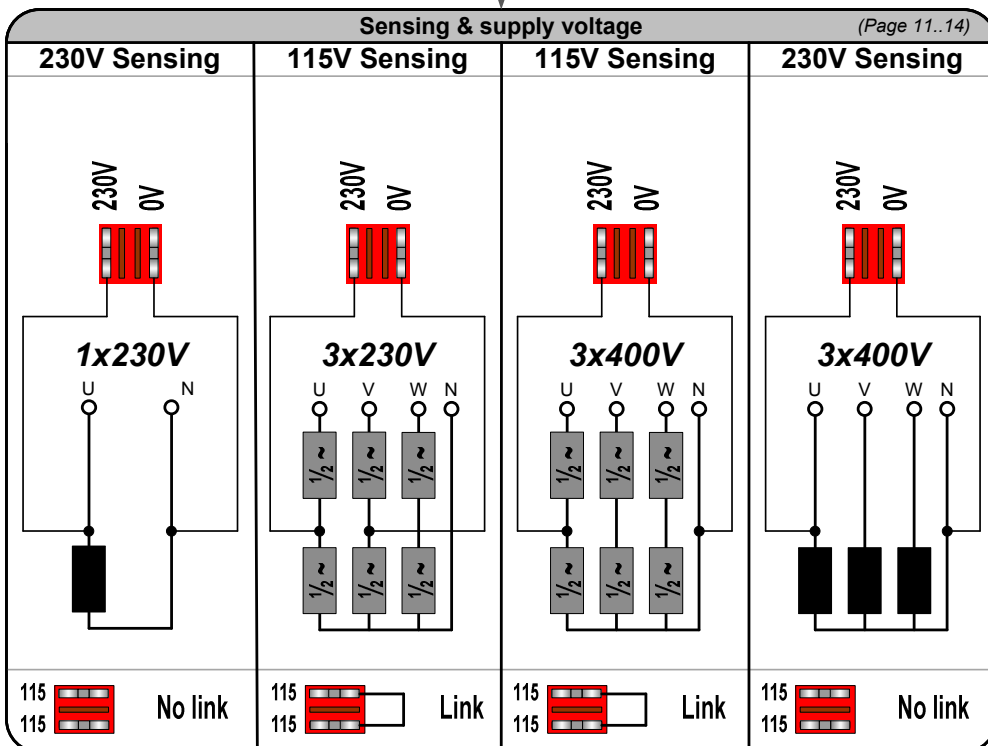

Exciter

Continuous 0..5A dc
Max. rating:
Intermitted 10A < 1s.

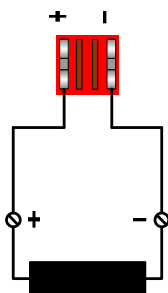

Exciter Field



Check Formula
Minimum field resistance

(Page 4)

COMMISSIONING SET UP

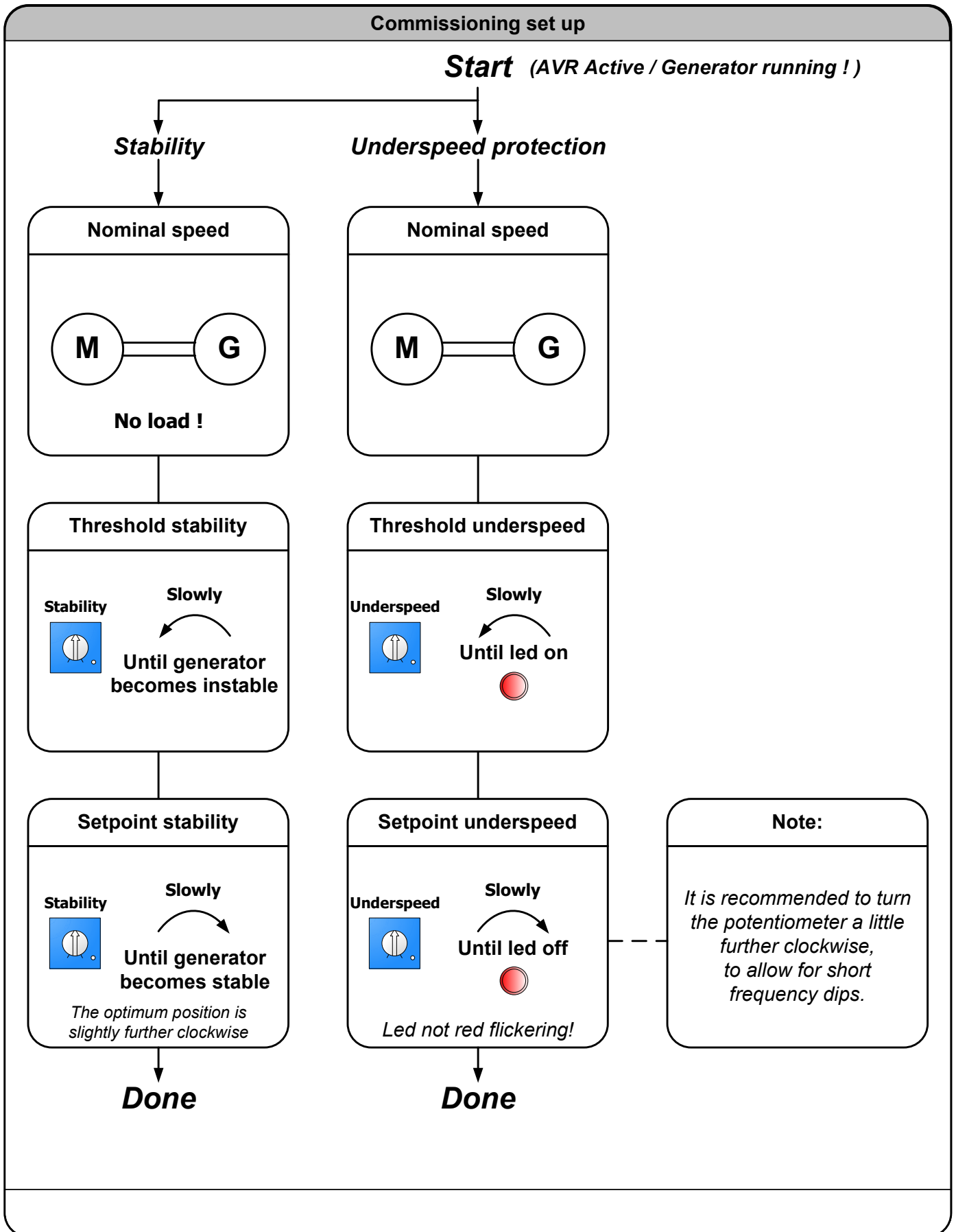

WIRING DIAGRAM I

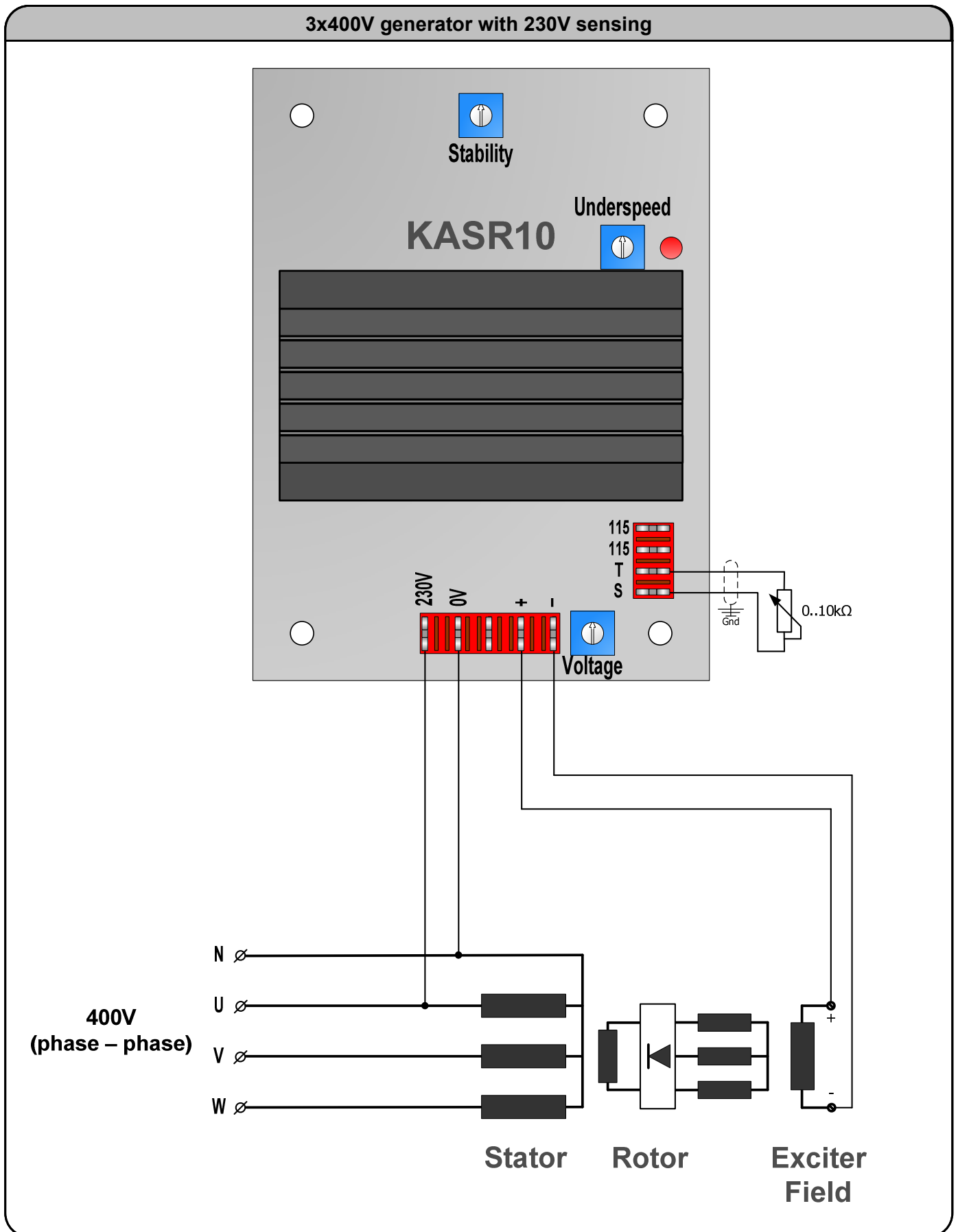

WIRING DIAGRAM I I

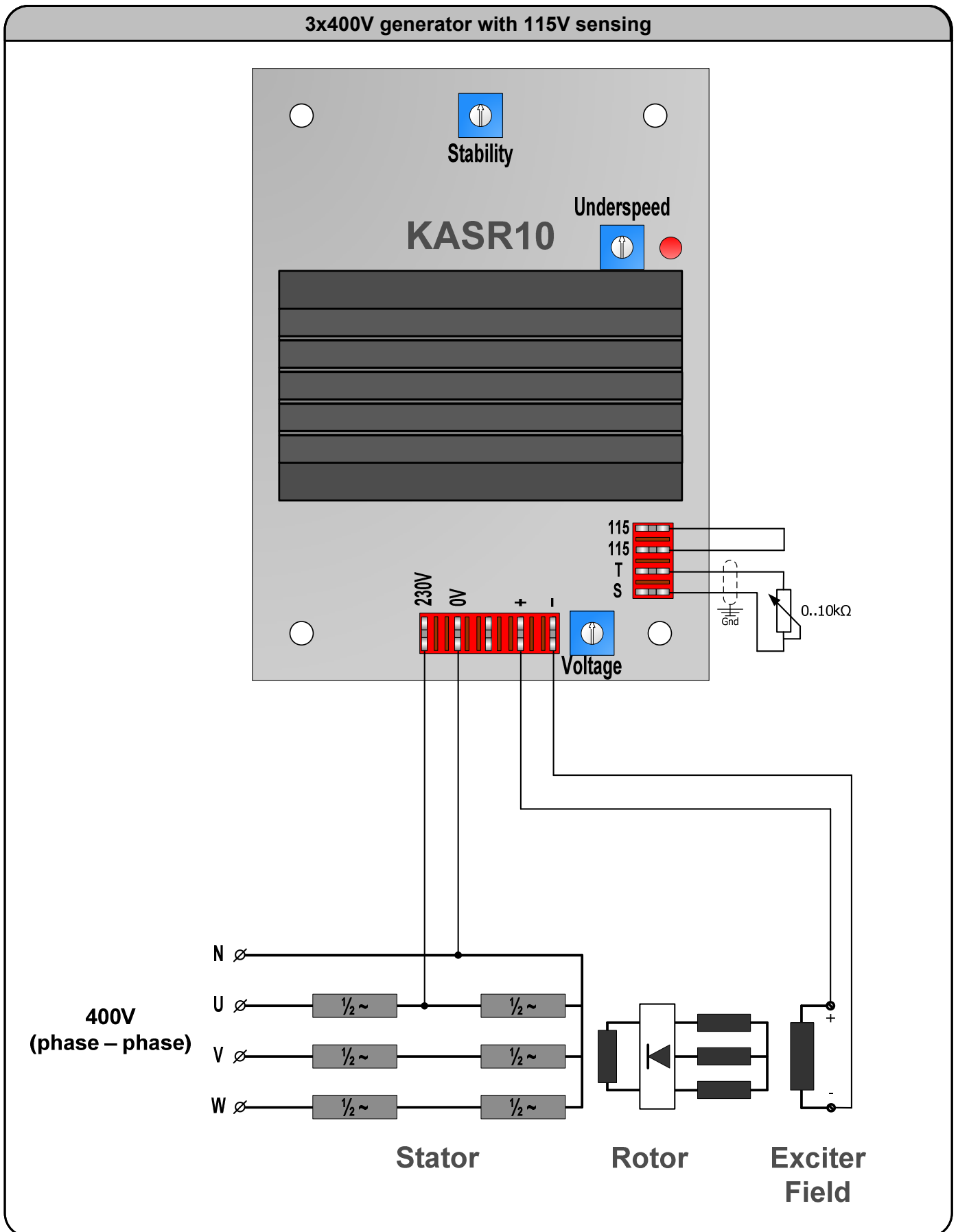

WIRING DIAGRAM I I I

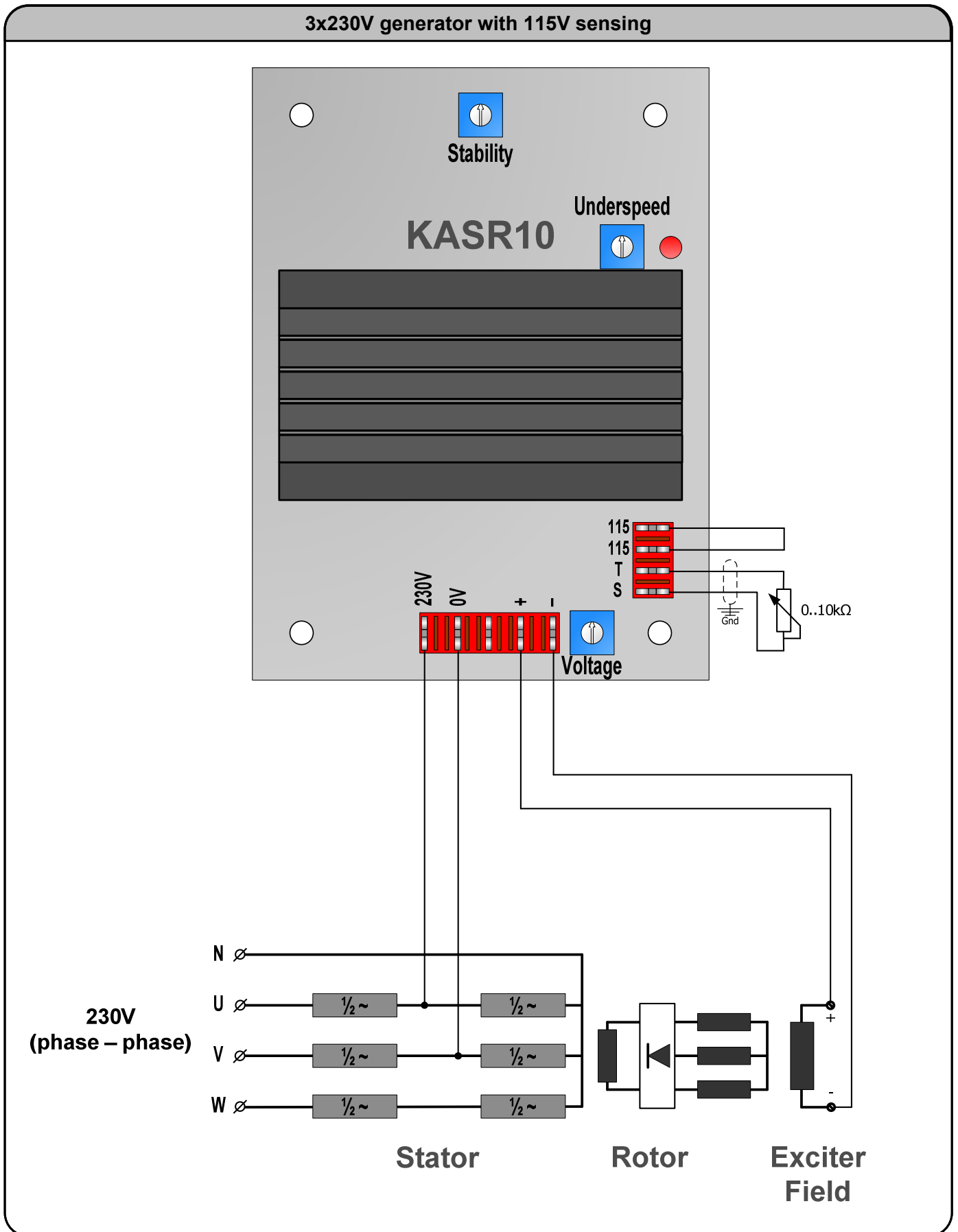

WIRING DIAGRAM I V

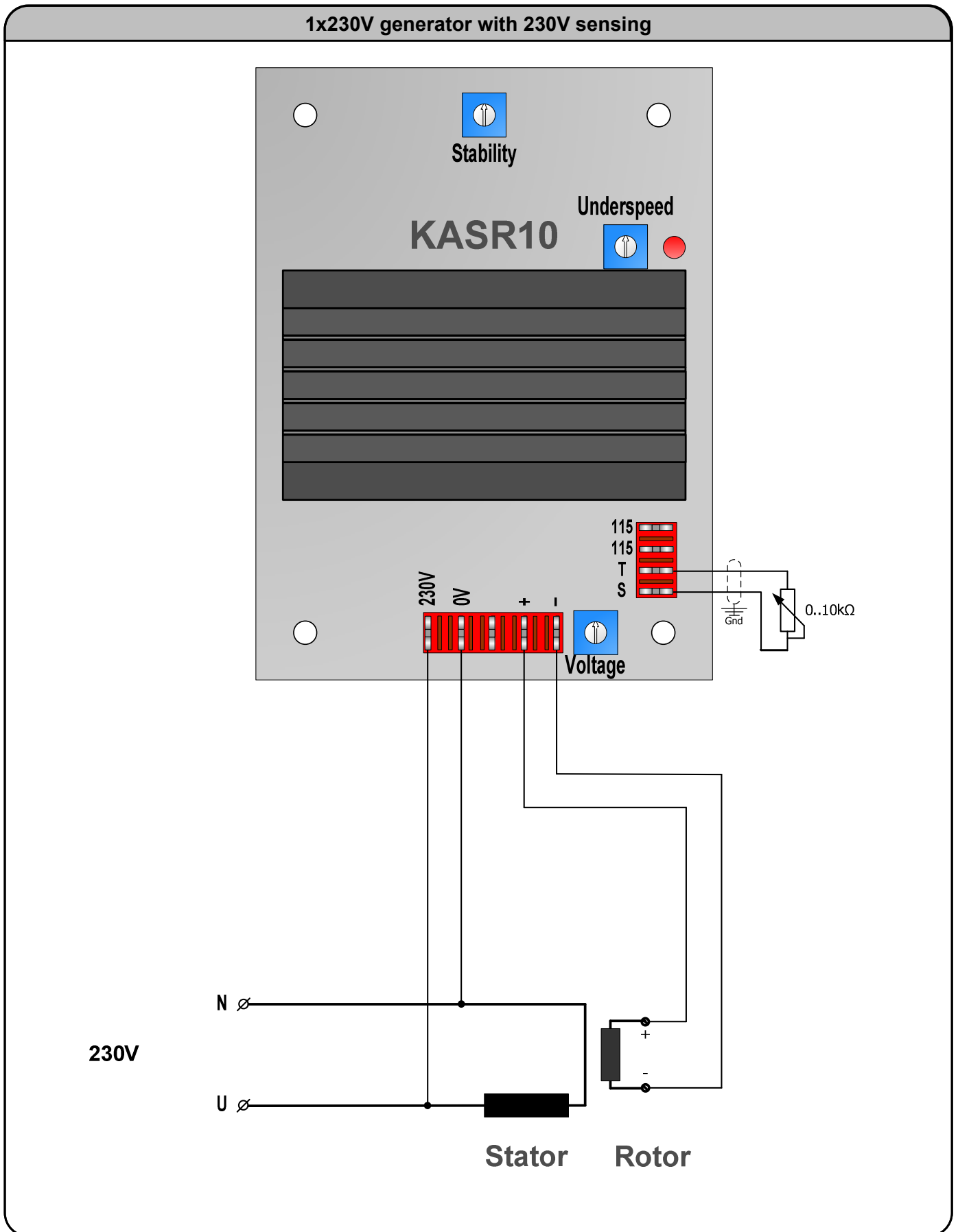

GENERAL INSTALLATION INFORMATION

Absolute Maximum Ratings

- The Absolute Maximum Ratings are those limits for the device that, if exceeded, will likely damage the device. Exceeding the absolute maximum ratings voids any warranty and/or guarantee.

Mounting

Mounting of the product should be done in such a way that:

- the absolute maximum ambient temperature rating of the product will never be exceeded.
- maximum cooling (direction of cooling ribs and direction of airflow) is achieved.
- Mounting no humid air can flow through the product or condensation occurs.
- dust or other materials or residue will not remain in or on the product.
- the maximum vibration is not exceeded.
- personal contact with persons is impossible.

Wiring

- Diameter size of the wiring should be enough to carry the expected current. Wire insulation should be enough to withstand the expected operating voltages and temperatures.
- To improve EMC emission and immunity, care should be taken for the lay out of the wiring. This in respect to all wiring in the installation.
- Keep current carrying wires as short as possible.
- Keep wires carrying a total sum of zero Ampere close to each other, or in one single cable, E.g. U, V, W, or X (+) and XX (-), or Phase and neutral, or S and T.
- Avoid current carrying conductors next to sensing or control wiring. Especially current controlled by SCR's or PWM controlled transistors.
- If sensitive sensing signal cables need to be laid across distance along other cabling, shielded cable is preferred. Keep the shield as long as possible and the wiring outside the shield as short as possible. Do not solder or shrink the shield to a regular wire. Connect the original shield to ground at one side with an as large as possible contact surface.

Additional installation information

- When the product is supplied by means of a transformer, it should never be an auto-transformer. Auto-transformers react as voltage sweep up coil and may cause high voltage peaks.
- Standard fit capacitors or over-voltage suppressers across X (+) and XX (-), or exciter field terminals inside the generator should be removed.
- When the product is supplied by means of a transformer, it should be able to carry at least the maximum expected current. Advisable is, to have a transformer which can carry twice the maximum expected current. Inductive loads make voltage sags and peaks into the secondary voltage of a transformer, from which the device may malfunction.
- It is not recommended to apply switches in dc outputs. It is preferred to use switches in the ac supply inputs of devices. In case it is unavoidable to have switches in the dc output of a device, action must be taken to avoid over voltage damage to the device due to contact arcing. Use a voltage suppressor across the output.
- It is not recommended to apply switches or fuses in the sensing lines. Defects can cause high voltage situations due to over-excitation.
- When using a step down transformer in medium or high voltage generators, the transformer should be three phase (if three phase sensing), and the transformer should be suitable for acting as a sensing transformer. If the transformer is unloaded, connect a resistor to avoid voltage waveform distortion.
- The phase relation from the generator to the AVR is important. Also when voltage transformers and/ or current transformers are installed.
- When using a step down or insulation transformer in the droop circuit, phase relation from the generator to the AVR is important.
- CT's wiring, connected to the AVR should never be grounded.
- Always disconnect electronic products, circuits and people before checking the insulation resistance (Megger check).
- Due to differences in generators impedance's, EMC behavior is not predictable. Therefore the commissioner / installer should be aware of proper and correct installation.
- Large, highly inductive, exciter stator windings can cause destructive high voltage peaks. Adding a resistor from 10 to 20 times the exciter stator field resistance reduces voltage spikes. If necessary filter can be fitted additionally. (e.g. snubber, RC-network)
- Upon problems during commissioning, faulty behavior or defects in the generator, consult the fault finding manual at our web site
- Some advises may be overdone or seem extraordinary, but since the electrical rules are the same everywhere, these advises are given.

CONTACT

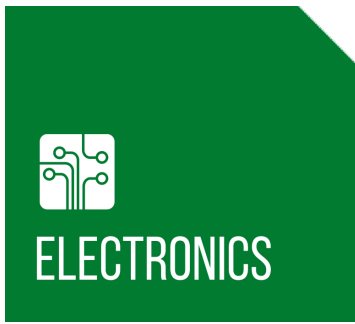

EMRI Electronics B.V.
Morsestraat 10
6716 AH, Ede, Netherlands
Tel: +31 (0)318 620 427
Website: www.emri.nl
E-mail: info@emri.nl

Manufacturer



CANARY ISLANDS, Las Palmas
Zamakona Yards
Tel: +34 928467521
Fax: +34 928461233
Website: www.zamakonayards.com/
E-mail: jbetancor@zamakonayards.com

CHILE, Santiago
Lucio Vicencio y CIA.LTDA
Tel: +1-281-334-2904
Fax: +1-832-221-5642
Website: www.luciovicencio.cl
E-mail: luciovincenciolt@gmail.com

GREECE, Piraeus
Stavros Kassidiaris S.A.
Tel: +30 210 4636000
Fax: +30 210 4624471
Website: www.kassidiaris.gr
E-mail: info@kassidiaris.gr

ICELAND, Hafnarfjordur
Rafeining ehf
Tel: +354 565 3049
Fax: +354 565 3048
Website: www.rafeining.is
E-mail: rafeining@rafeining.is

INDIA, Faridabad
Power Solutions
Tel: +91 9868907903
Fax: +91 129 2431216
Website: www.psolindia.com
E-mail: ramesh.powersolutions@gmail.com

NORWAY, Bergen
Frydenbø Electric A/S
Tel: +47 55 34 91 00
Fax: +47 55 34 91 10
Website: www.frydenbo.no
E-mail: firma.fel@frydenboe.no

POLAND, Gdynia
An-Elec Sp. z o.o.
Tel: +48 58 668 44 00
Fax: +48 58 668 44 66
Website: <http://an-elec.pl>
E-mail: info@an-elec.pl

POLAND, Szczecin
MARCONTROL
Tel: +48 91 4 888 474
Fax: +48 91 4 888 475
Website: www.marcontrol.com
E-mail: emri@marcontrol.com

POLAND, Szczecin-Mierzyn
Marel Serwis
Tel: +48 91 48 58 388
Fax: +48 91 48 79 948
Website: www.marel.szczecin.pl
E-mail: handel@marel.szczecin.pl

REPUBLIC OF PANAMA, Panama
PASRAS S.A.
Tel: +507 3140095
Fax: +507 3140094
Website: www.pasras.com
E-mail: info@pasras.com

ROMANIA, Constanta
SAMTEC SRL
Tel: +40 241 517 047
Fax: +40 241 517 047
Website: www.samtec.ro
E-mail: samtec_srl@yahoo.com

SINGAPORE, Singapore
Cyclelect Electrical Engineering
Tel: +65 6868 6013
Fax: +65 6863 6260
Website: www.cyclelect.com.sg
E-mail: heng.p@cyclelect.com.sg

SOUTH AFRICA, Roodepoort
Yneldo Electronics
Tel: +27(0)117637053
Fax: +27(0)117634212
Website: www.yneldo.com
E-mail: yneldo@yneldo.com

SWEDEN, Kungälv
Elektrisk Drivteknik EDT AB
Tel: +46-705-28 20 60
Tel: +46-709-50 47 90
Website: www.edtab.se
E-mail: info@edtab.se

THAILAND, Bang Lamung
Semtec Maritime/Genetech Co.Ltd
Tel: +66 38301262
Fax: +1-832-221-5642
Website: semtecmaritime.com/
Email: info@semtecmaritime.com

TURKEY, Izmir
INTEGRAL
Tel: +90 (555) 211 55 75
Email: ozgur@integralguc.com

UNITED ARAB EMIRATES, Sharjah
KDU Technical Services
Tel: +971-6-5575480
Fax: +971-6-5575490
Website: www.kdutech.ae
E-mail: kdutech@kdutech.ae

UNITED KINGDOM, Stockton on Tees
MJR Controls
Tel: +44 1642 762 151
Fax: +44 1642 762 502
Website: www.mjrcontrols.com
Email: chris.milner@mjrcontrols.com

UNITED KINGDOM, Cheadle Hulme
TGS Total Generator Solutions Ltd
Tel: +44161 8188720
Fax: +447754677963
Website: <http://totalgeneratorsolutions.com>
Email: sales@totalgeneratorsolutions.com

UNITED STATES, Kemah - Texas
Ramtec Marine Systems LLC
Tel: +1-281-334-2904
Fax: +1-832-221-5642
Website: www.ramtec-marine.com
Email: waling@ramtec-marine.com